

MINIATURES SERIES

B-TYPE LONDON OMNIBUS 1919

38031



GENERAL INSTRUCTION

1:35

- HIGHLY DETAILED MODEL
- ACCURATE ENGINE
- CLEAR PARTS INCLUDED
- PHOTO-ETCHED PARTS INCLUDED
- DECAL SHEET INCLUDED
- 8 OPTIONS SIDE ADVERT
- 3 OPTIONS FRONT ADVERT
- 3 OPTIONS REAR ADVERT

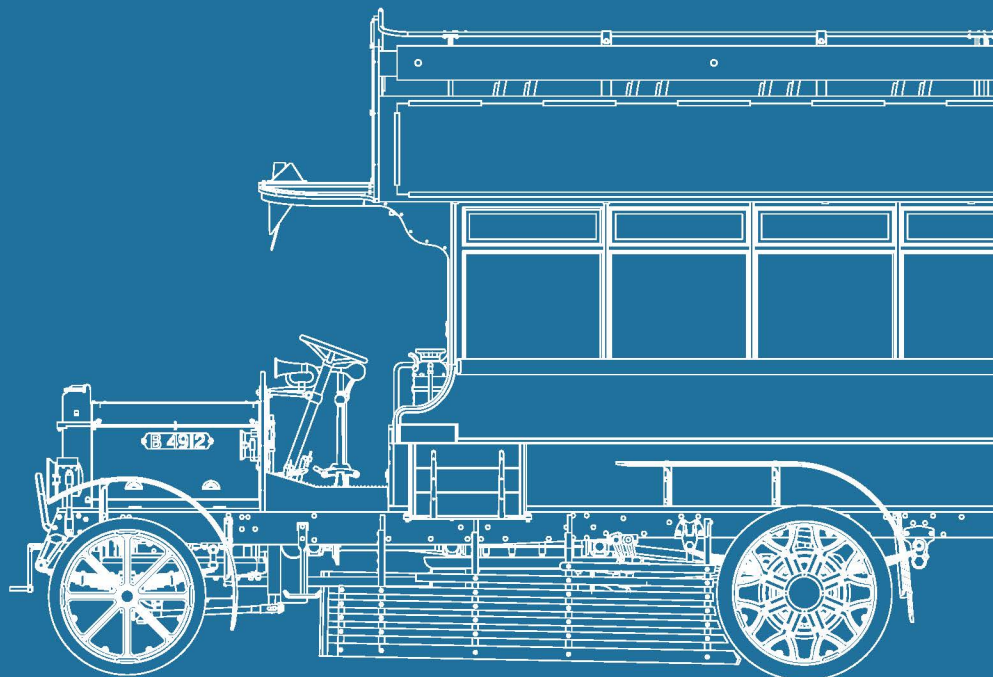

PAINTING GUIDE

1 London, 1920's.



PAINTING GUIDE

1 London, 1920's.

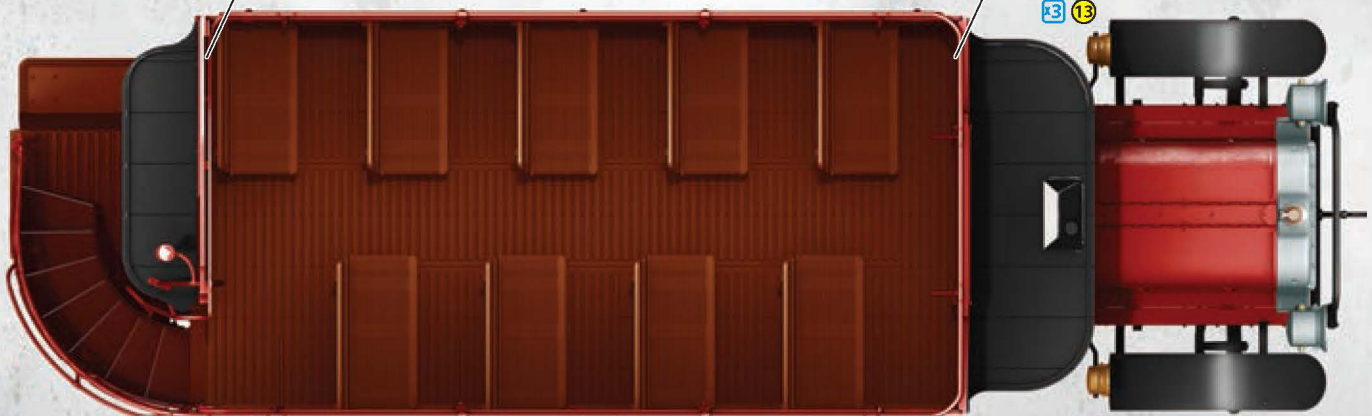
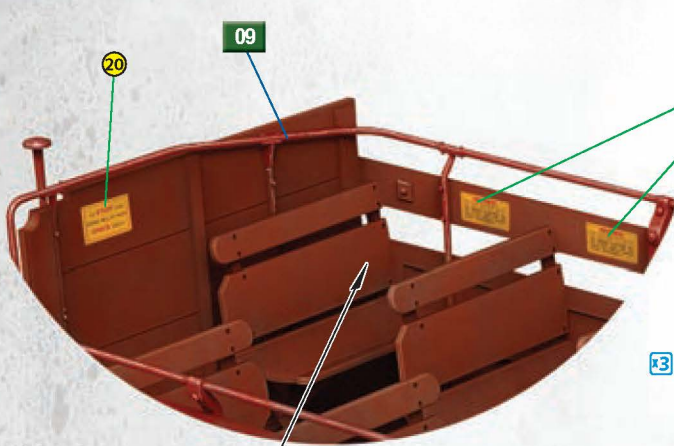
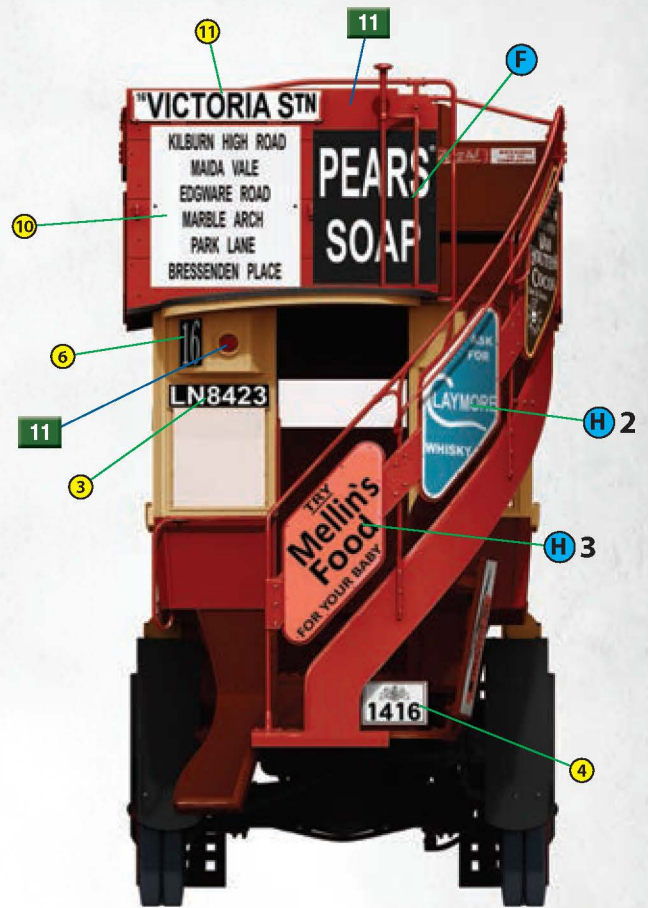
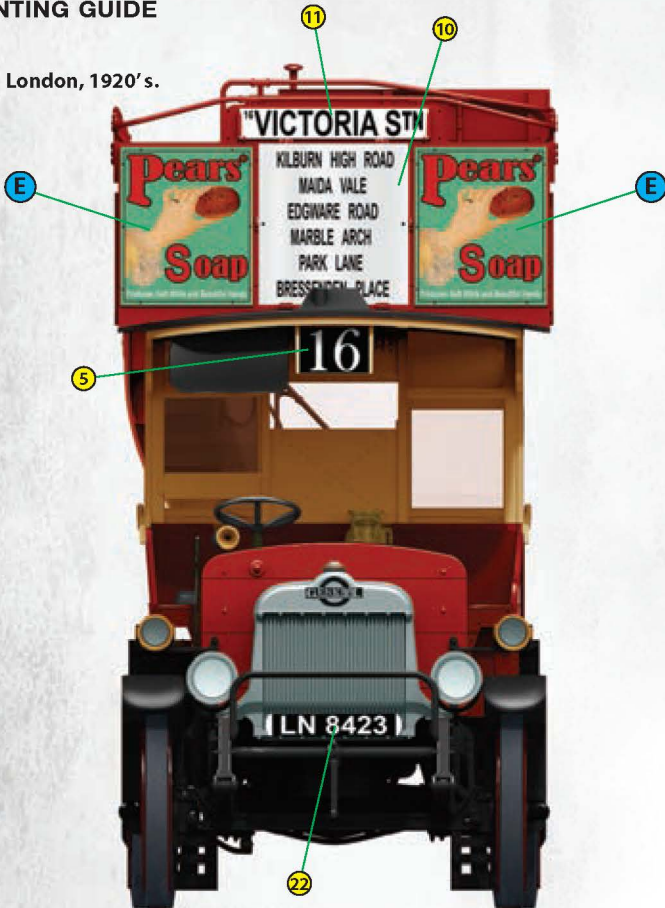

PAINTING GUIDE

2 London, 1920's.

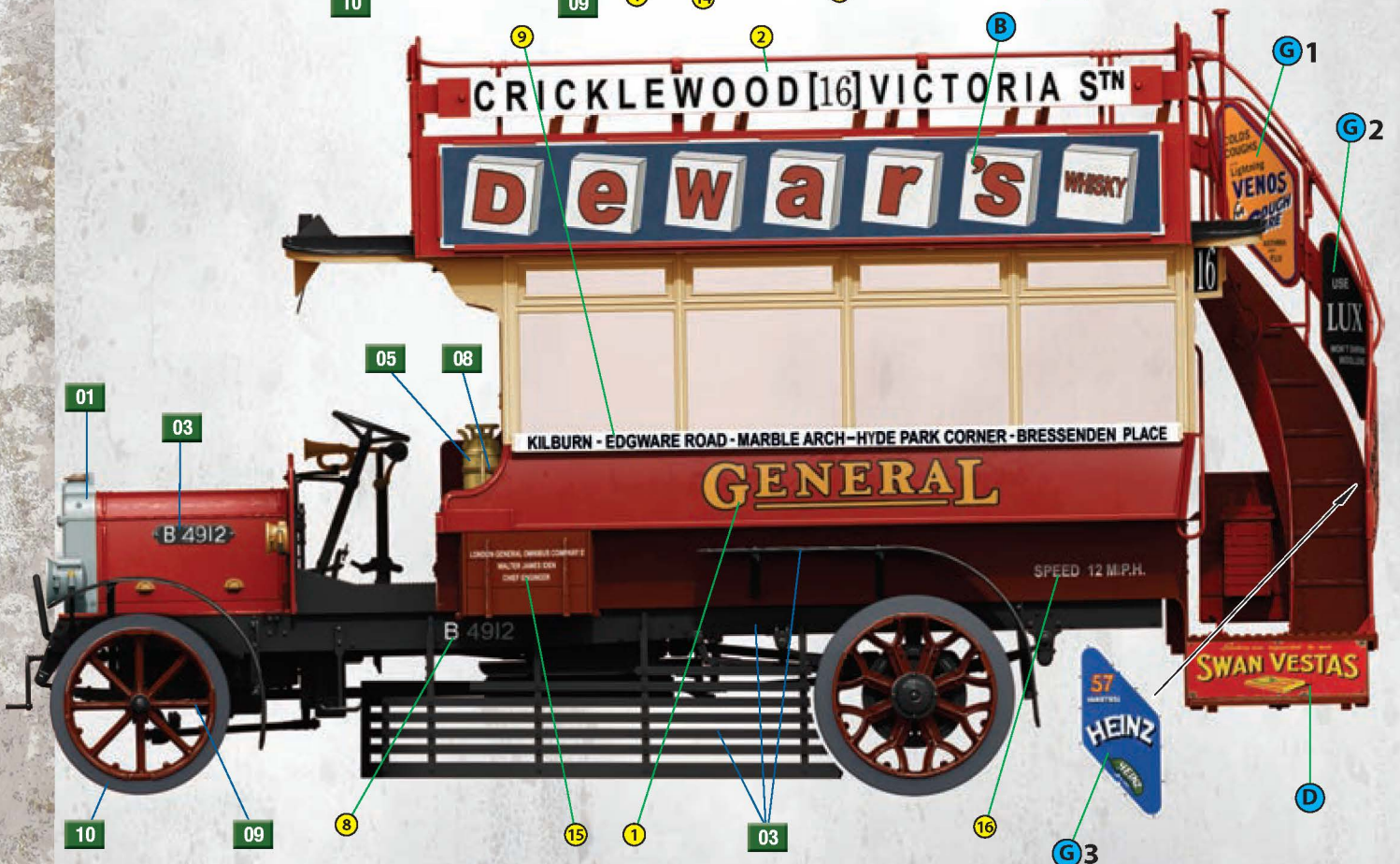

PAINTING GUIDE

2 London, 1920's.



COLOR CHART

Nº	Color	Vallejo	Mr. Color	AK RC	Mission Models	AMMO MIG	Tamiya	Color name
01		71.062	C-090	RC-020	MMM-008	A.MIG-0194	XF-16	Aluminium
02		71.073	C-078	RC-015	MMM-001	A.MIG-0045	XF-84	Gun Metal
03		71.057	C-033	RC-001	MMP-047	A.MIG-0046	XF-01	Black
04		71.001	C-062	RC-004	MMP-001	A.MIG-0050	XF-02	White
05		71.068	C-010	RC 016	MMM-004	A.MIG-0199	XF-06	Copper
06		71.080	C-131	AK-709	MMW-001	A.MIG-0041	XF-10	Dark Rust
07		71.327	C-111	RC-088	MMP-006	A.MIG-0027	XF-15	Beige
08		71.041	C-310	RC-035	MMP-033	A.MIG-0076	XF-10	Brown
09		71.818	C-029	RC-067	MMP-012	A.MIG-0913	XF-64	Red Braun
10		71.251	C-137	RC-022	MMP-040	A.MIG-0033	XF-85	Tire Black
11		71.003	C-003	RC-006	MMP-003	A.MIG-0049	XF-07	Red

ATTENTION

Ne pas utiliser de colle ou de peinture a proximité d'une flamme nue, et aérer la pièce de temps en temps.
 Pour retirer les pièces hors du cadre, utiliser des ciseaux spéciaux pour maquette le plastique en excès avec un cutter ou une lime.
 Voir la fin de cette colonne pour la signification des symboles.
 Après l'assemblage peut rester des pièces inutilisées.

ZUR BEACHTUNG

Kleber und Farbe nicht nahe von offenem Feuer verwenden und das Fenster von Zeit zu Zeit zur Belüftung öffnen.
 Zum Abschneiden der Teile vom Verbundstück eine Modellerschere verwenden und die überstehenden Plastikteile mit einem Messer oder einer Feile beseitigen.
 Die Bedeutung der Symbols finden Sie unten in dieser Spalte.
 Nach dem Zusammenbau des Modells, können einzelne Teile übrig bleiben

УВАГА

При використанні клею та фарб всі роботи проводити подалі від джерел вогню у приміщенні, що добре провітрюється.
 Деталі відокремлювати від літників ножем або іншим ріжучим інструментом. Зачистити облої і місця зрізу за допомогою надфілю та наждачного паперу. Будівництво моделі виконувати згідно зі схемою. Для зручності побудови кожна деталь позначена номером.
 Після складання можуть залишитися невикористані деталі.

ATTENZIONE

Non usare colla e vernice vicino a fiamme esposte, e aprire le finestre di tanto in tanto per cambiare l'aria. Quando si staccano parti del carrello, usare forbici da modellismo e eliminare la plastica in eccesso con un coltello o una lima. Vedere in fondo a questa colonna per il signifi. Dopo l'assemblaggio possono rimanere parti inutilizzate.

ВНИМАНИЕ

При использовании клея и красок все работы производить в проветриваемом помещении вдали от источников огня. Детали отделять от литников ножом или другим режущим инструментом. Зачистить облои и места среза при помощи надфиля и наждачной бумаги. Сборку моделей производить согласно схеме сборки.
 Для удобства сборки каждая деталь обозначена номером. После сборки набора могут остаться неиспользованные детали.

CAUTION

When you use glue or paint, do not use near open flame, and use in well ventilated room. When you take parts off from the runner frame, use modeling scissors or cutter.
 See the bottom of this column for the meaning of symbols.
 Extra details can remain after assembling of the kit.

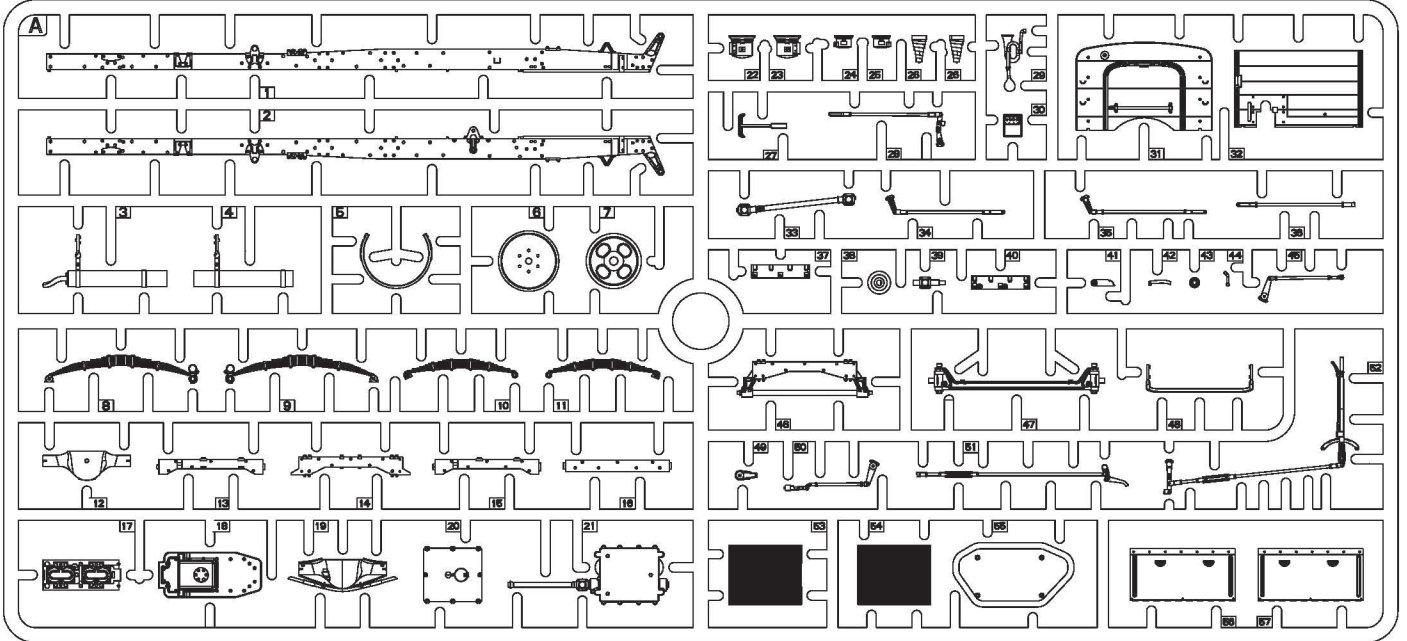
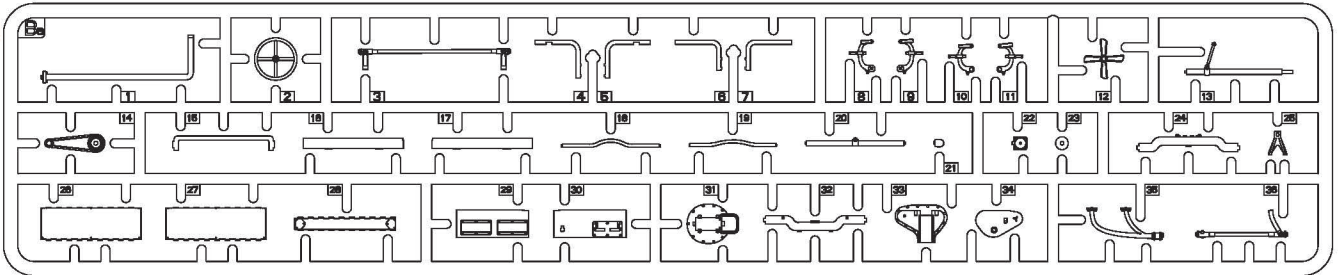
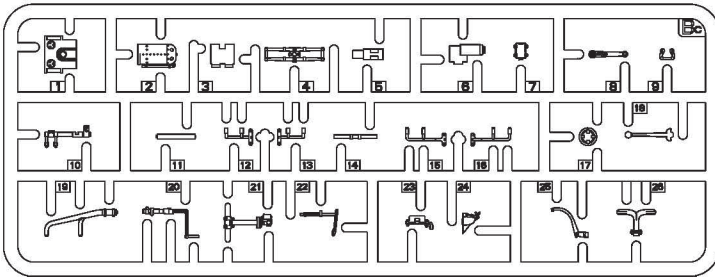
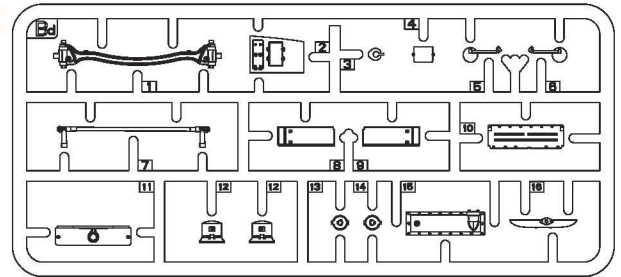
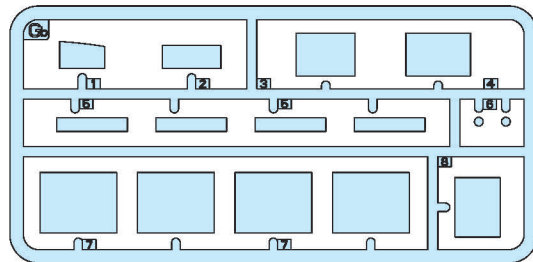
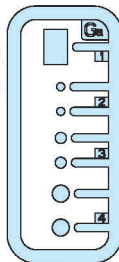
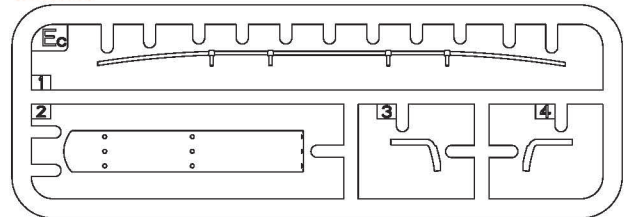
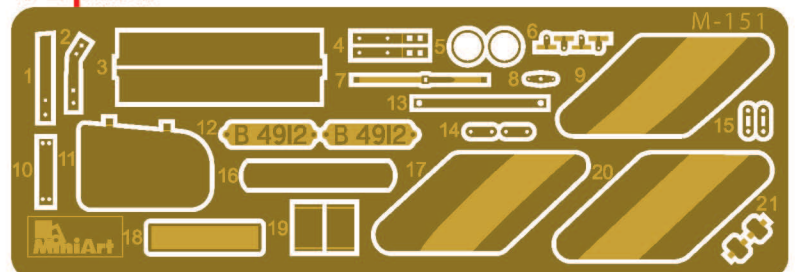
PARTS**A****Ba****Bc****Bd****Gb x2 (Clear parts)****Ga (Clear parts)****Ec x2****Decal****PE parts**



MAKE 2PCS
2 TEILE FERTIGEN
EFFECTUER 2 PIECES
FARE DUE PEZZI
TEE 2 KPL
GÖR 2 ST.
ПОВТОРИТЬ ДВА РАЗА
КІЛКІСТЬ РАЗІВ



DO NOT CEMENT
NICHT KLEBEN
NE PAS COLLER
NON INCOLLARE
EILIMÄÄ
LIMÄEJ
НЕ ИСПОЛЬЗОВАТЬ КЛЕЙ
НЕ КЛЕЇТИ



OPTIONAL
NACH BELIEBEN
FACULTATIF
FACOLTATIVO
VALINNANVARAINEN
VALBAR
ВАРИАНТЫ
ВАРІАНТИ



OPEN HOLE
OFFENEN
FAIRE UN TROU
FORO APERTO
AVAA REIKÄ
OPRNA HALET
СДЕЛАТЬ ОТВЕРСТИЕ
ЗРОБИТИ ОТВІР



REMOVE
ENTFERNEN
RETIRER
SEPARARE
POISTA
AVLÄGSNA
ОТРЕЗАТЬ
ВІДРІЗАТИ



BEND
BITTE BIEGEN
PLIER S'IL VOUS PLAÏT
PIEGARE
TALTA
BOČKA
ВЫГНУТЬ
ВИГНУТИ



SCRATCH/BUILD
AM MEISTEN ZU MACHEN
FAIRE LE PLUS
RENDITI
RENDITI
GÖR DIG SJÄLV
СДЕЛАТЬ САМОМУ
ЗРОБИТИ САМОМУ

PARTS

C

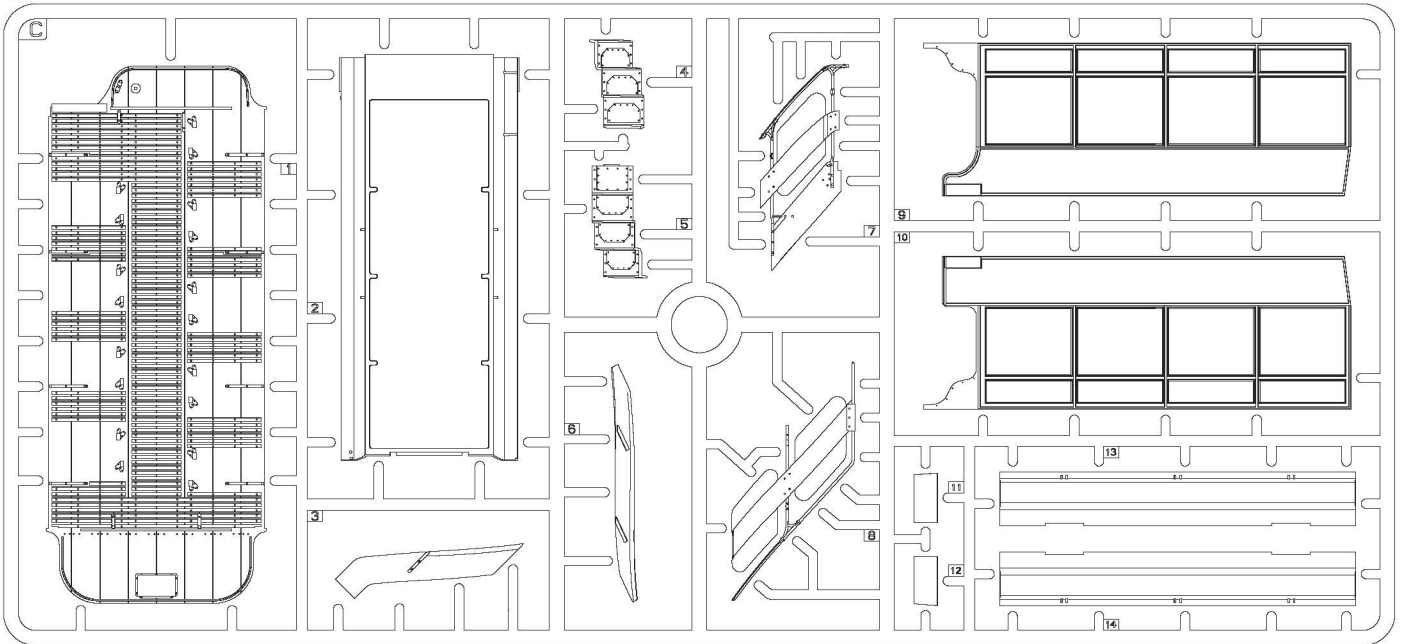

D

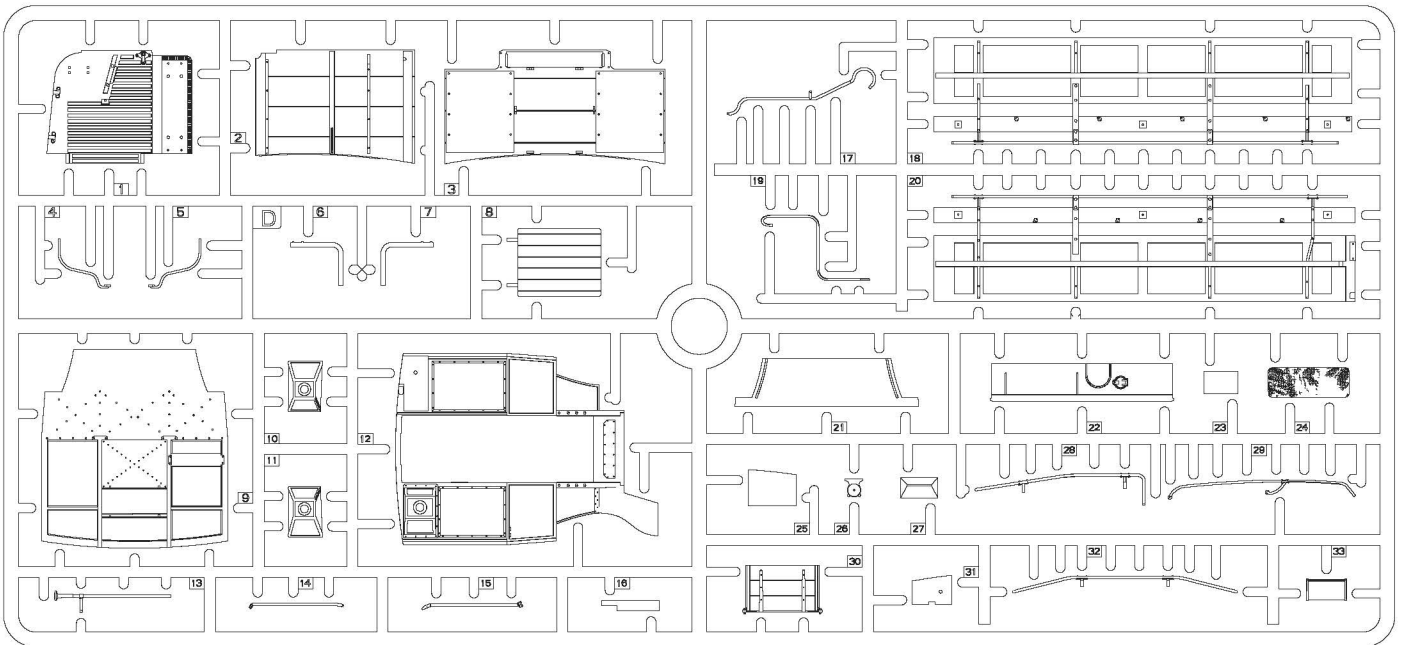

Ea x4

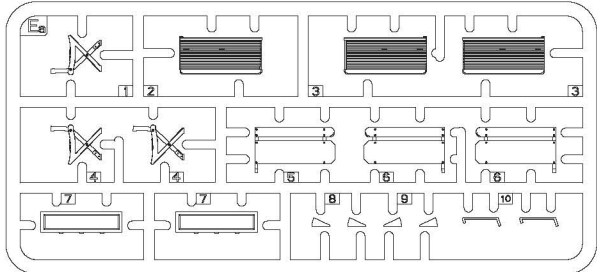

Eb x4

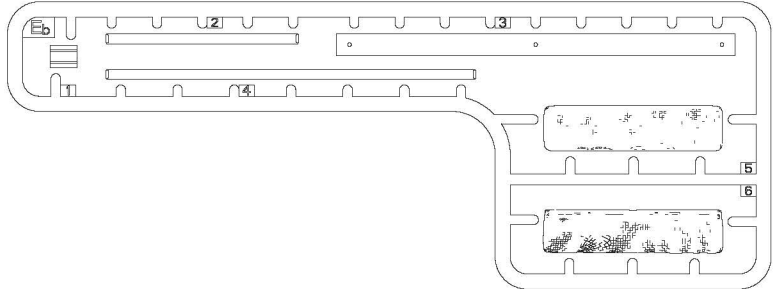

Ed x2

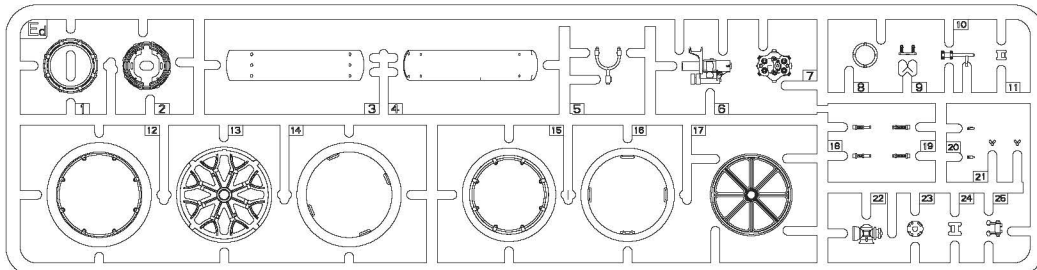

Hb

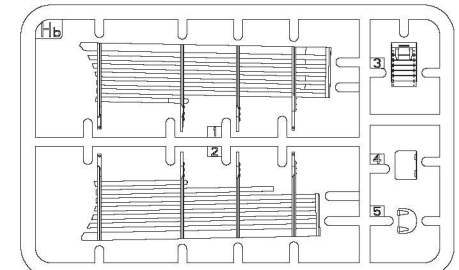

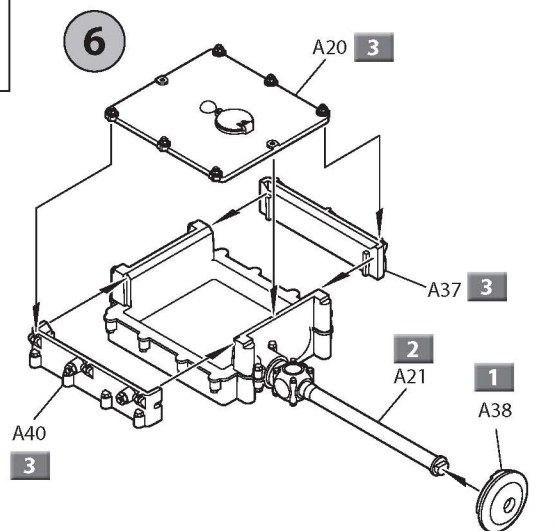
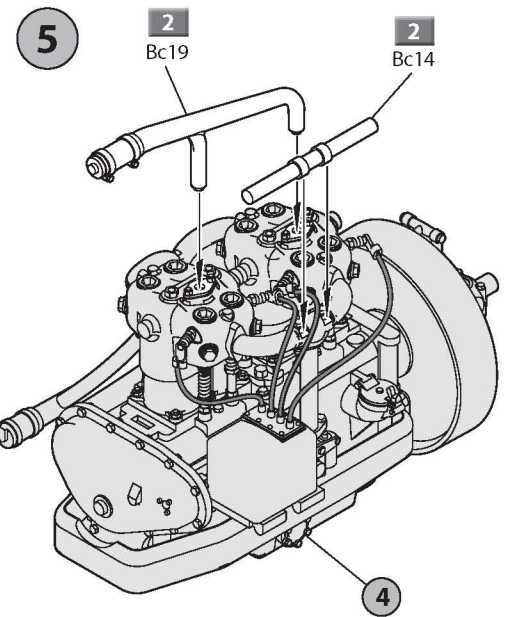
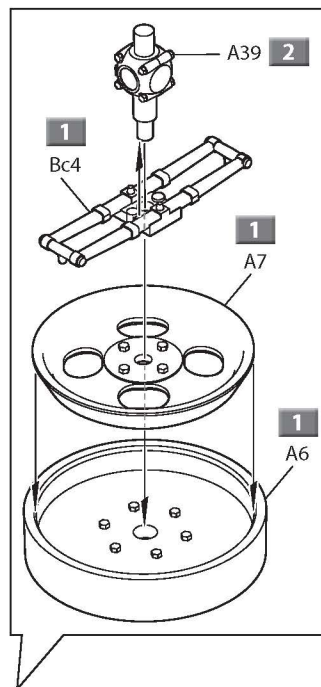
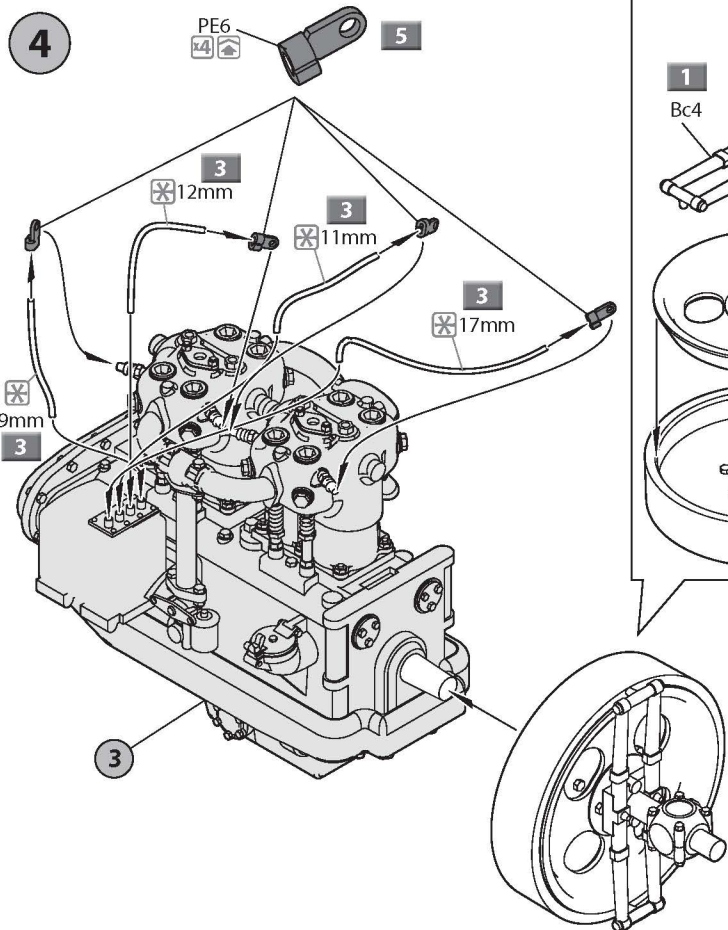
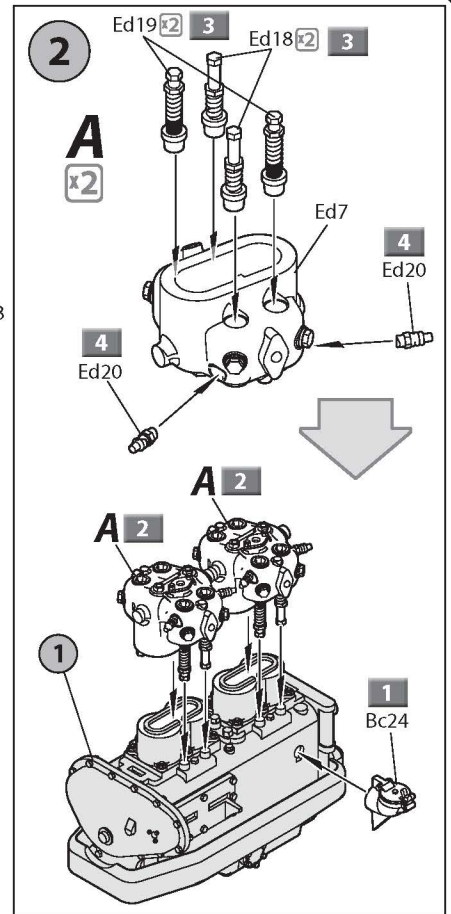
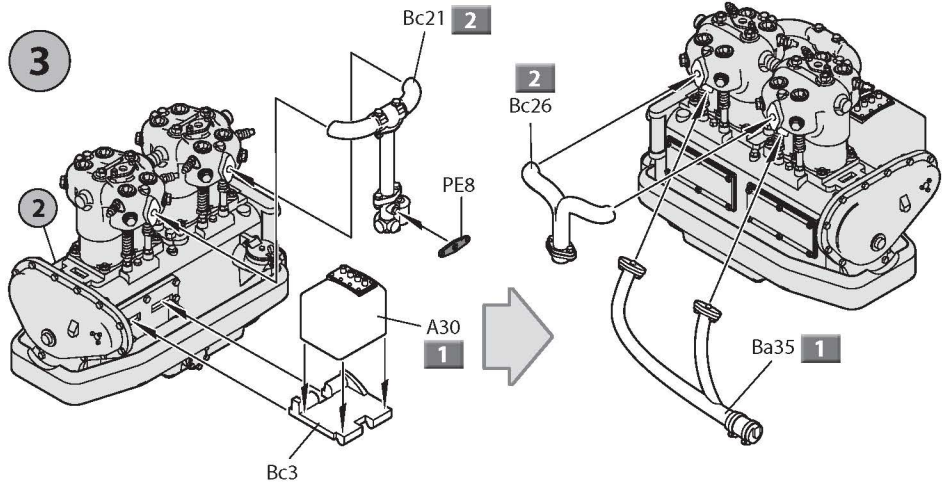
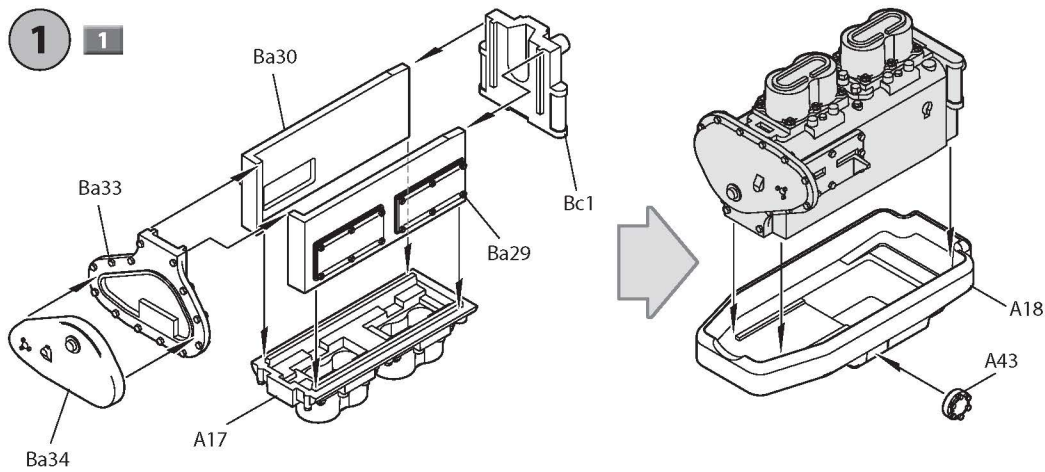

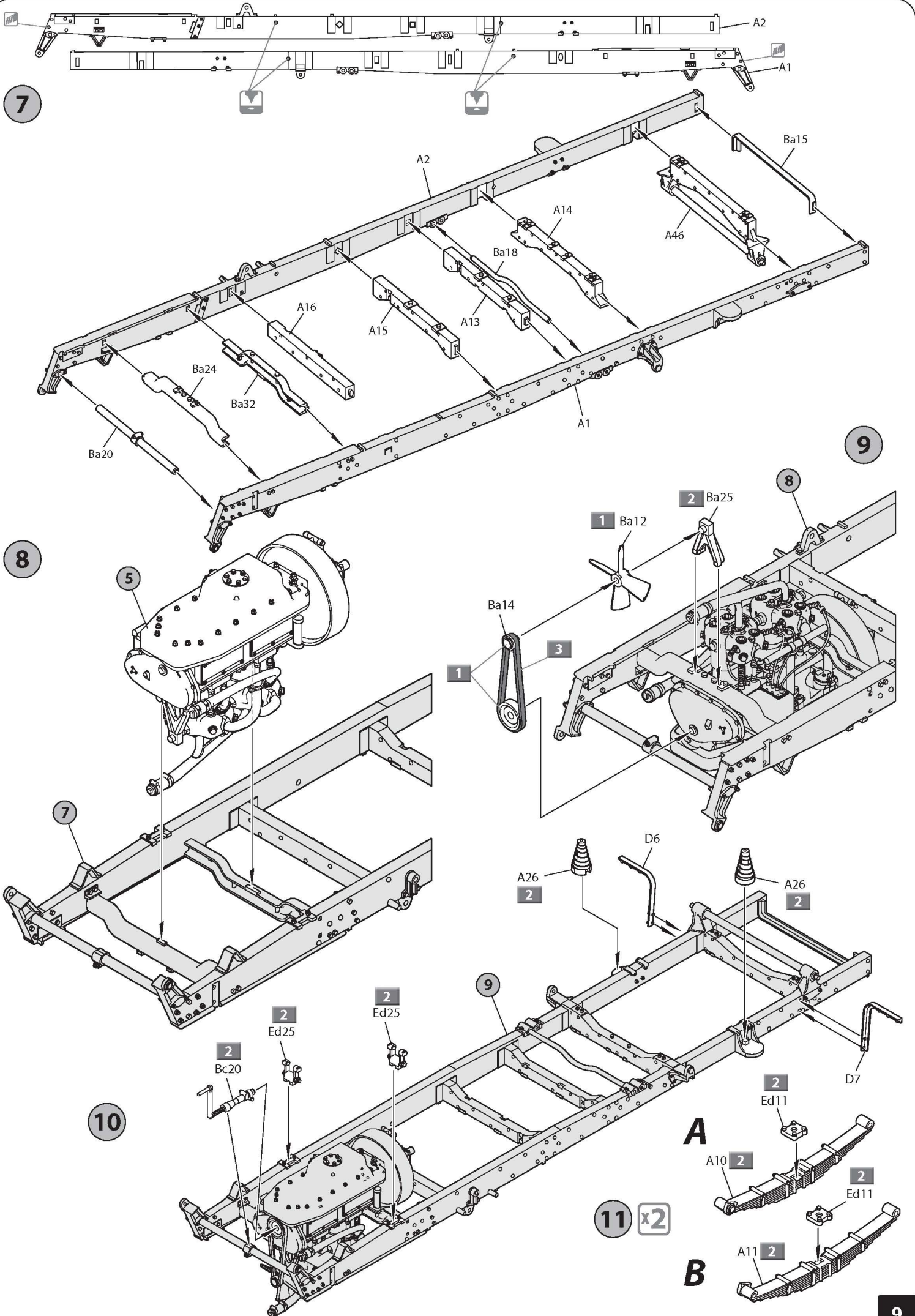

12

C

D

D

C

11 B

11 A

10

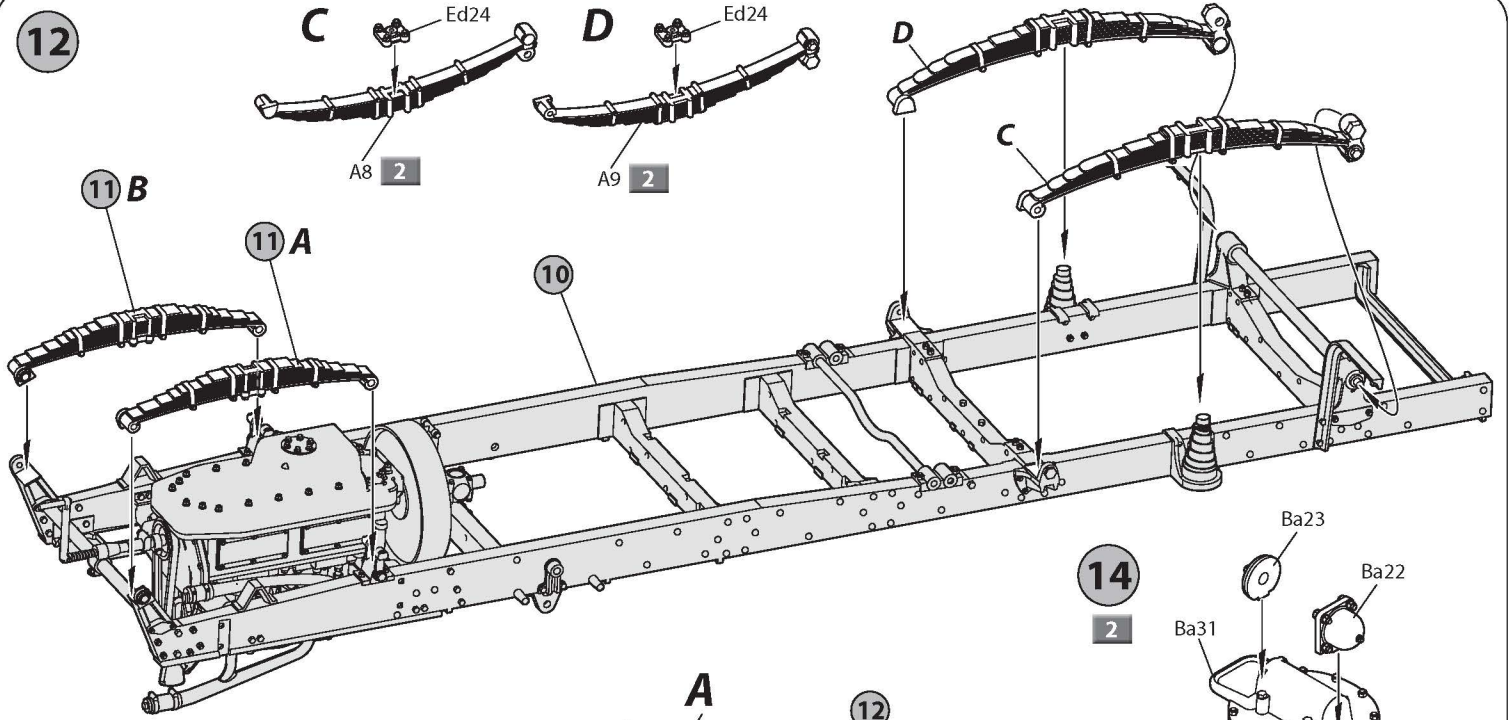

14

2

Ba23

Ba22

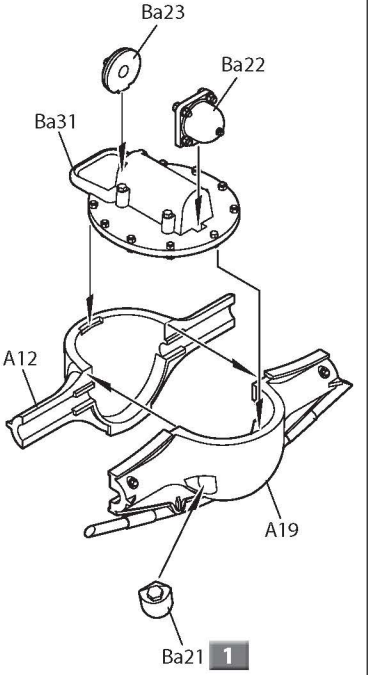

13

A

A

12

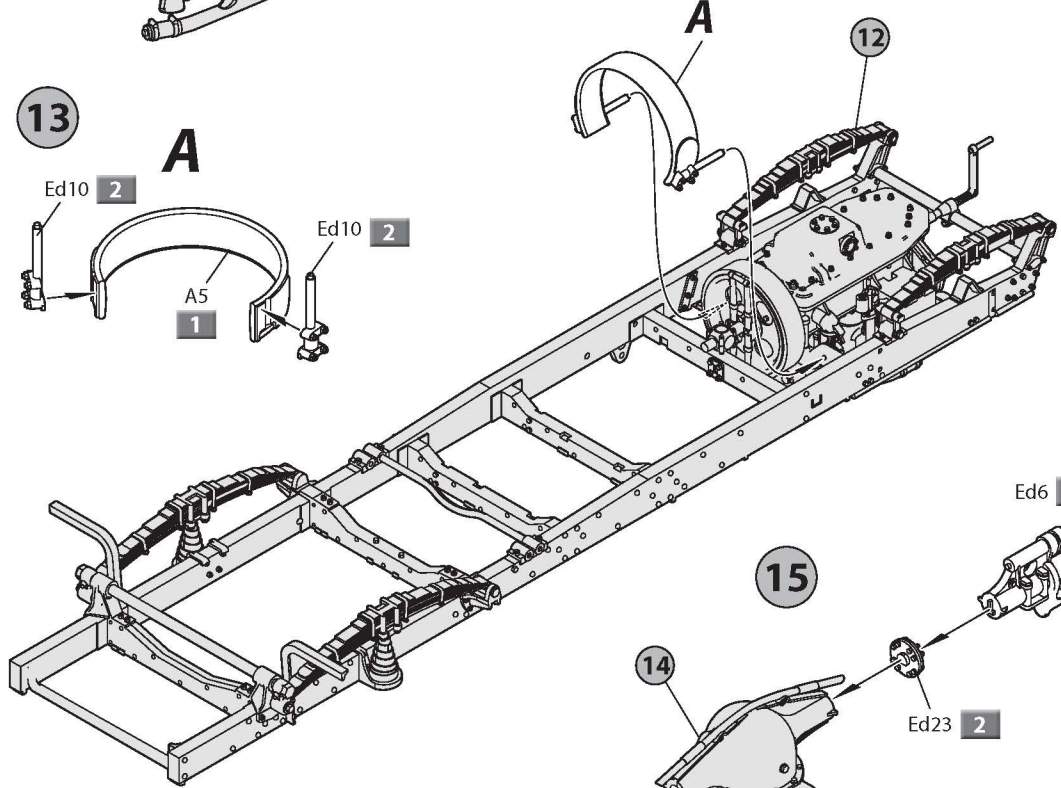
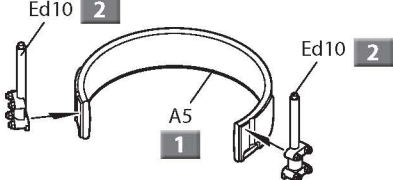

Ed6 2

15

14

Ed23 2

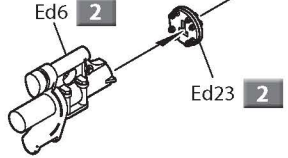

17

16

A50 2

2 A45

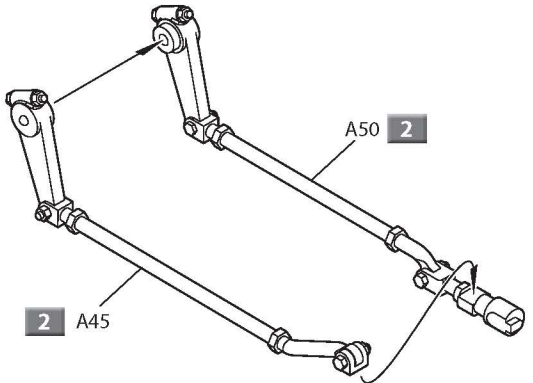

13

15

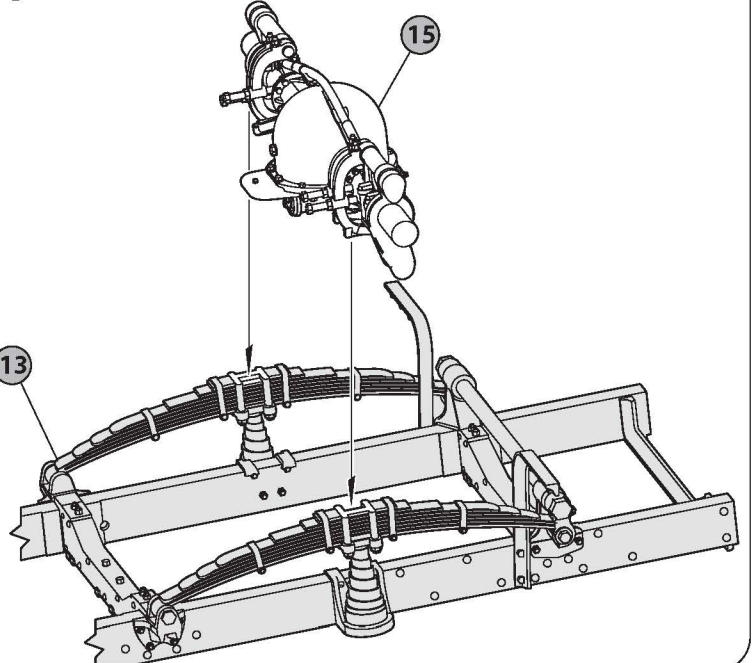

10

18

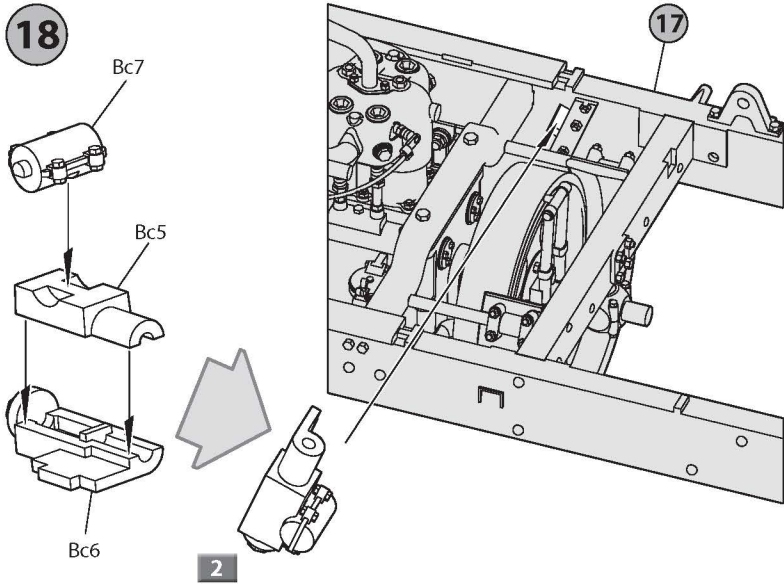

19

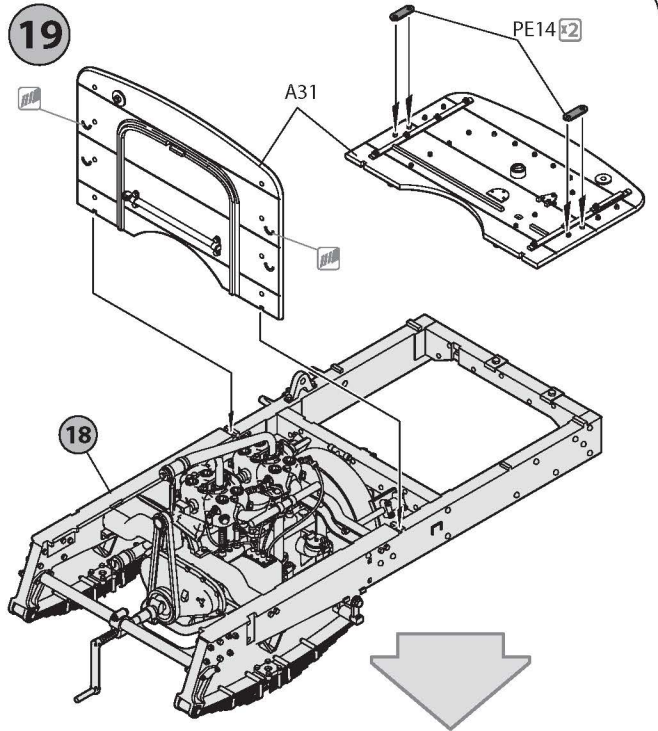

20

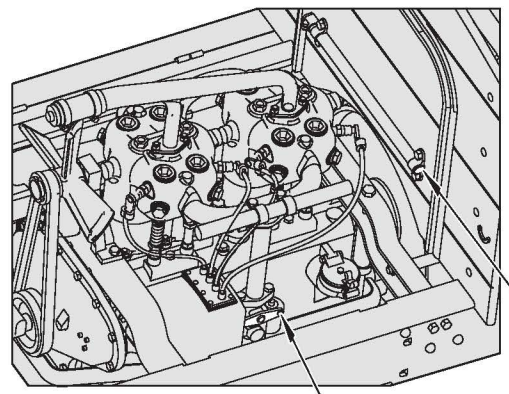
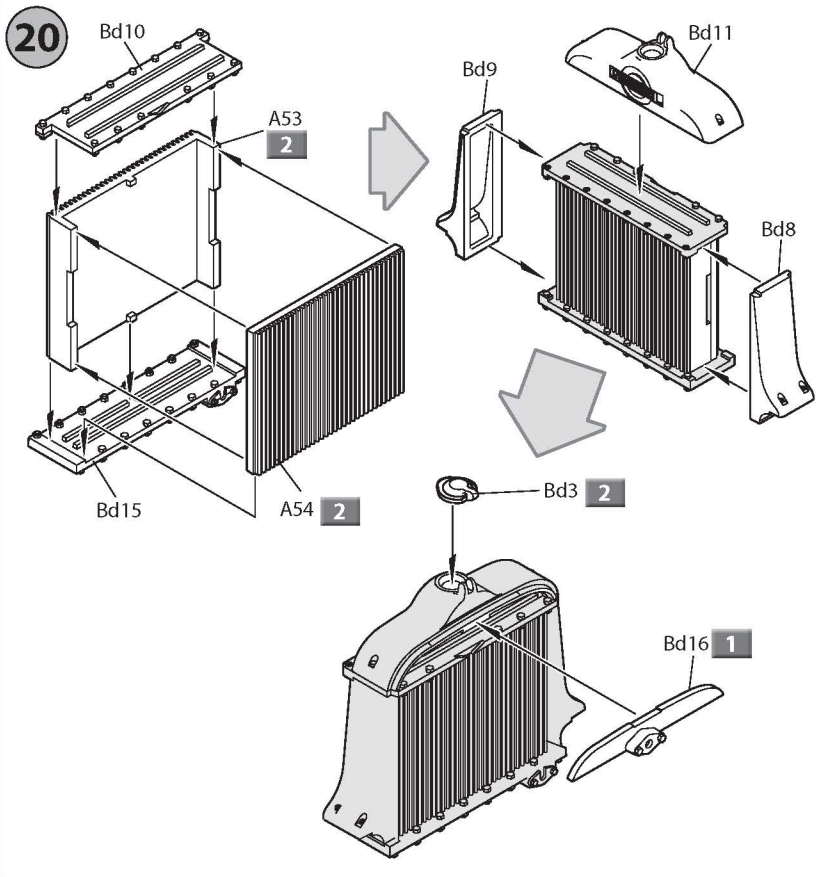

Wire $\phi - 0,3 \text{ mm}$, L - 19 mm
Scale 3:1

Scale 1:1

A44 2

21

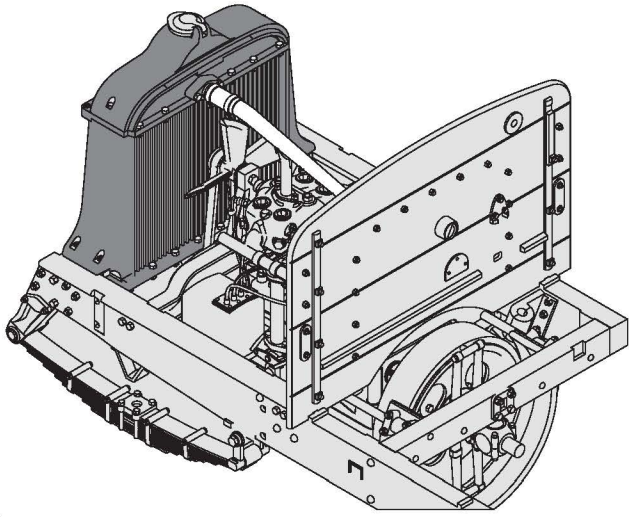
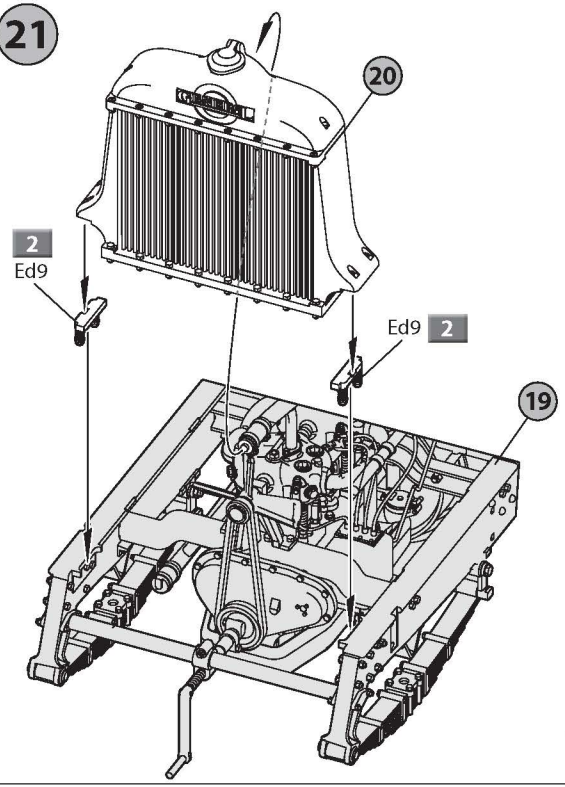

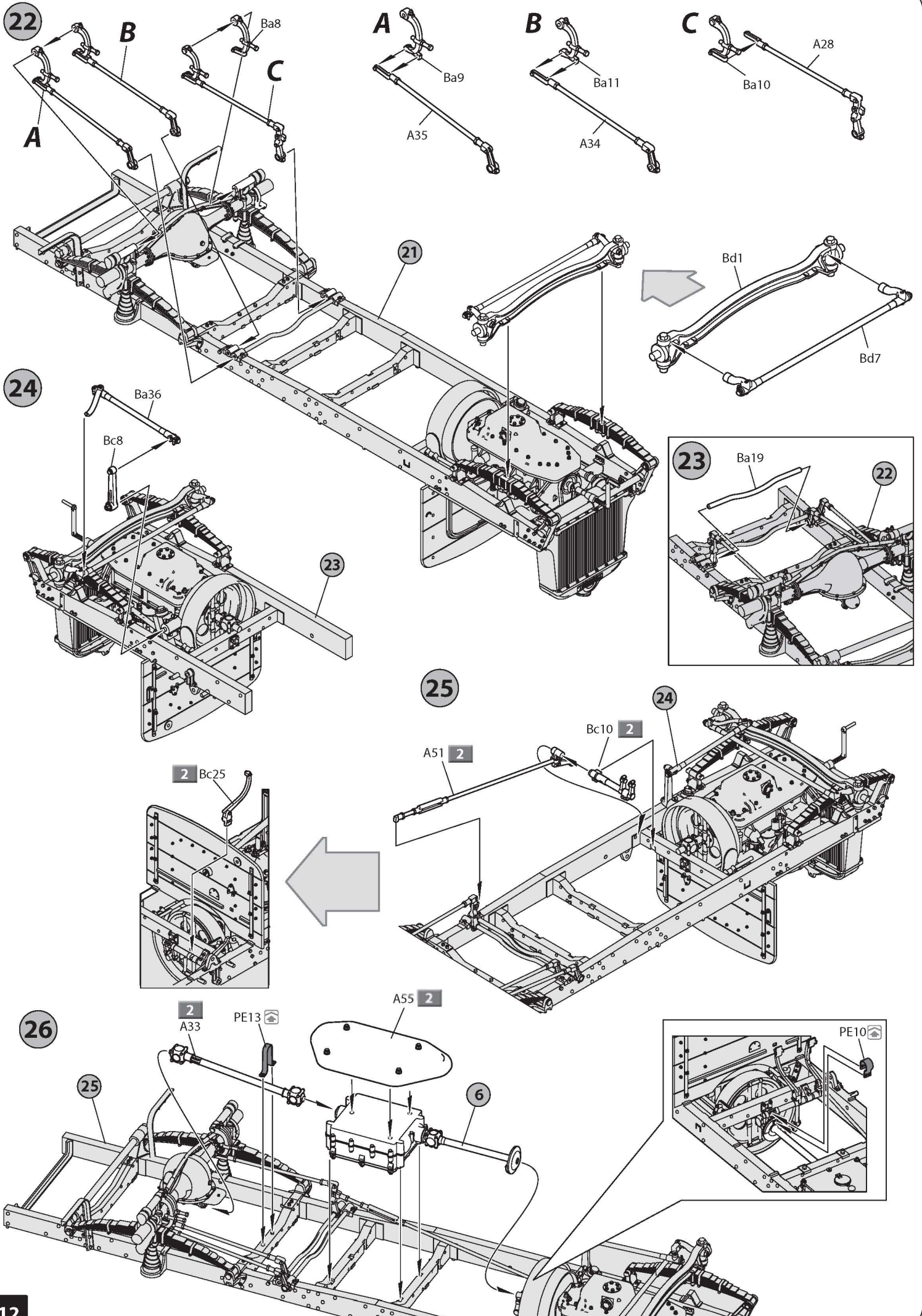

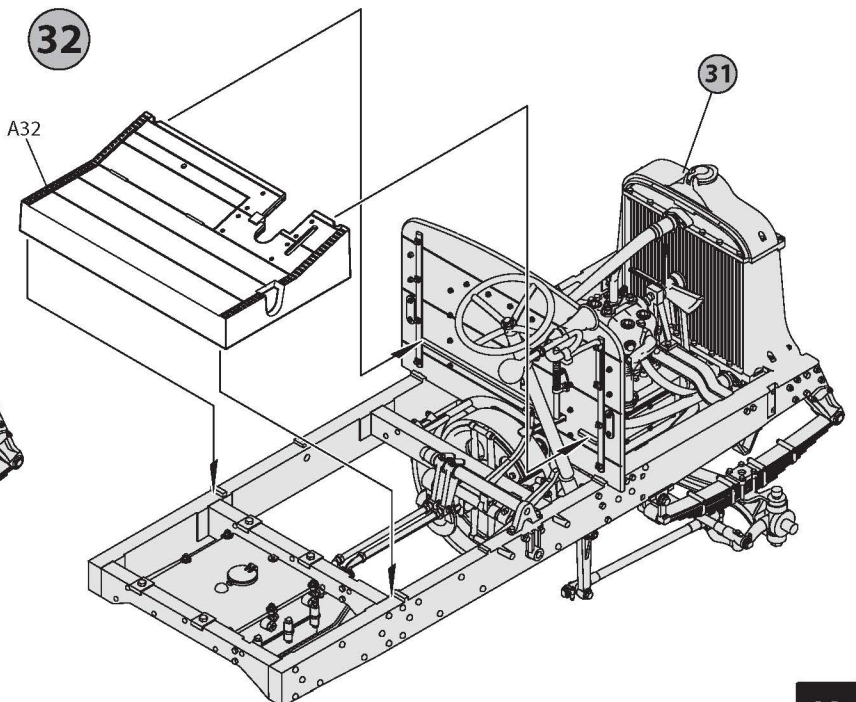
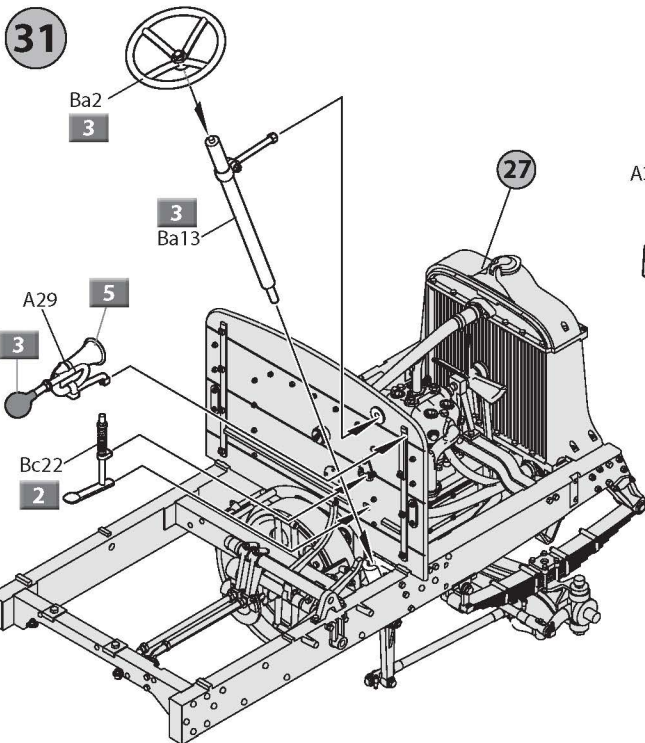
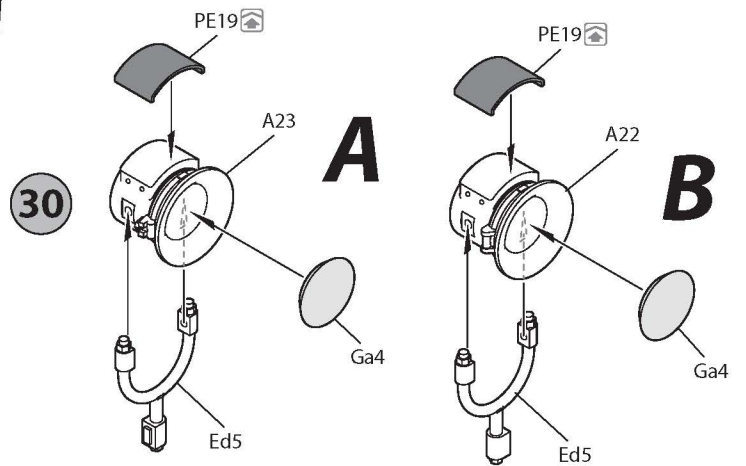
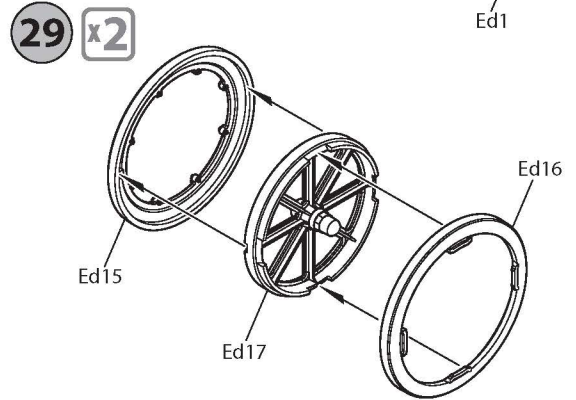
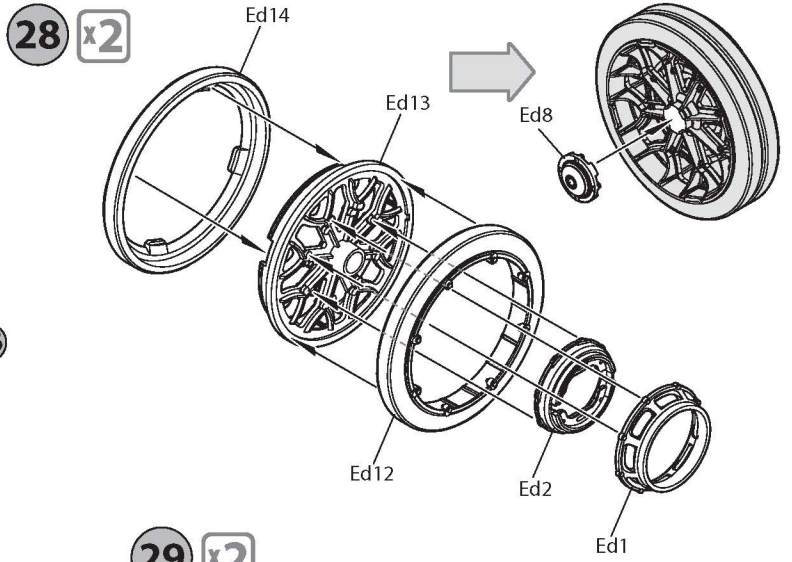
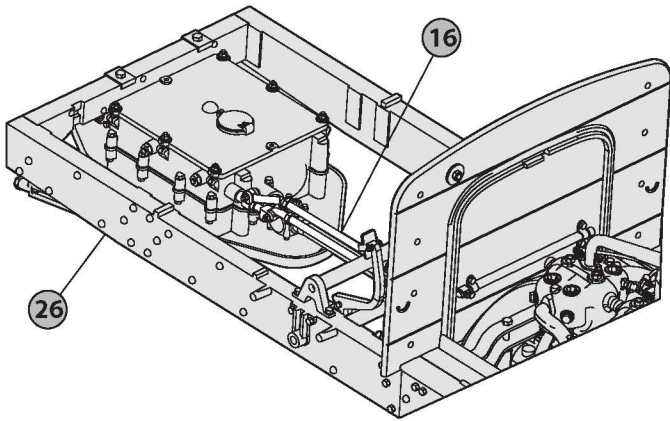
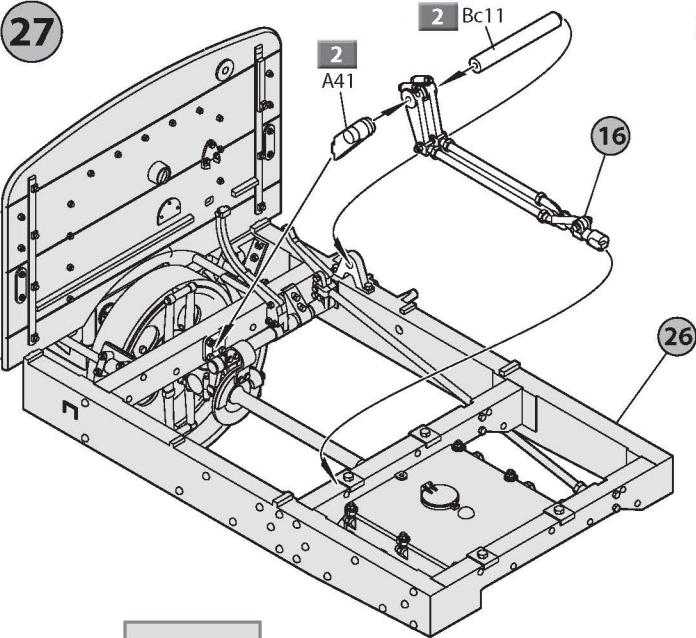

33

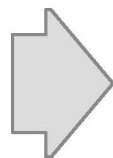
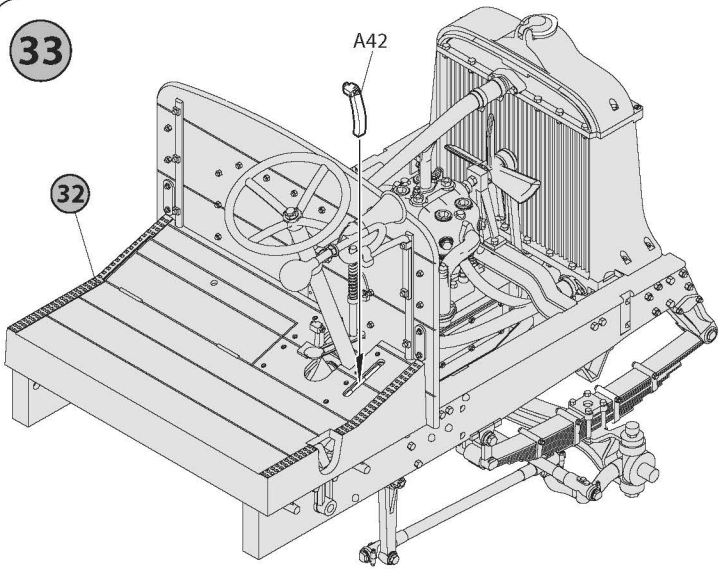

PE21 x2

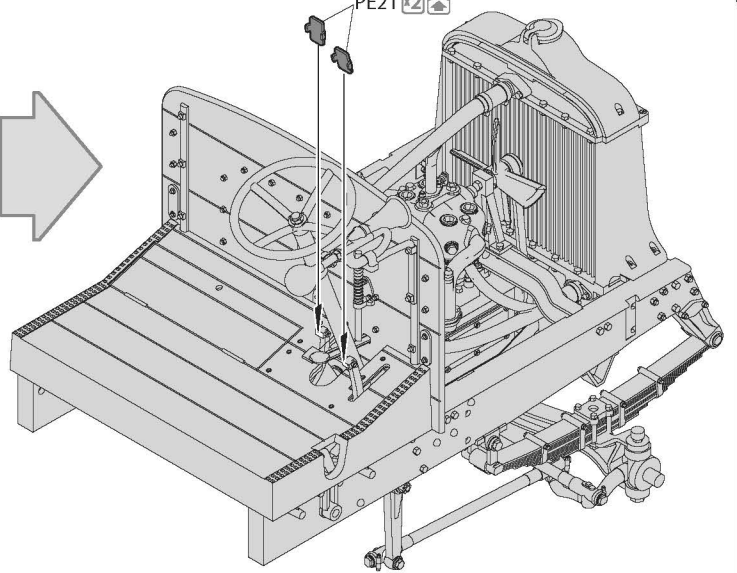

34 x2

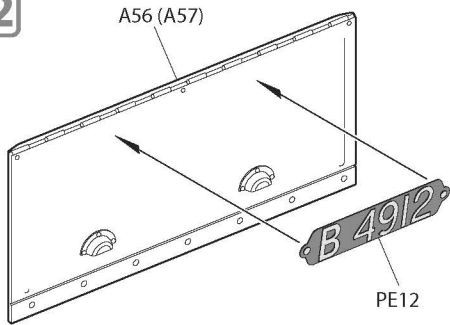

35

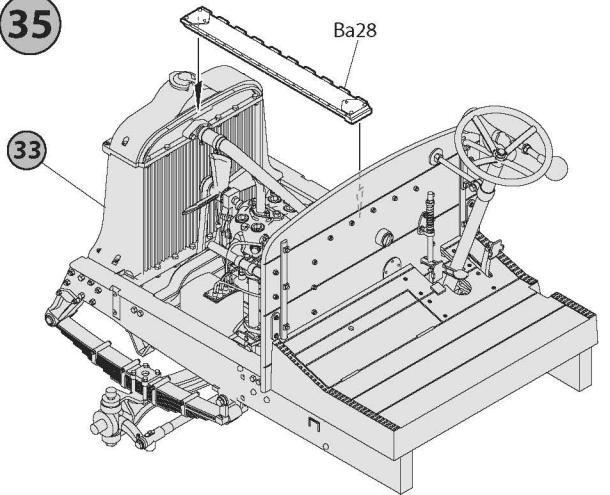

36

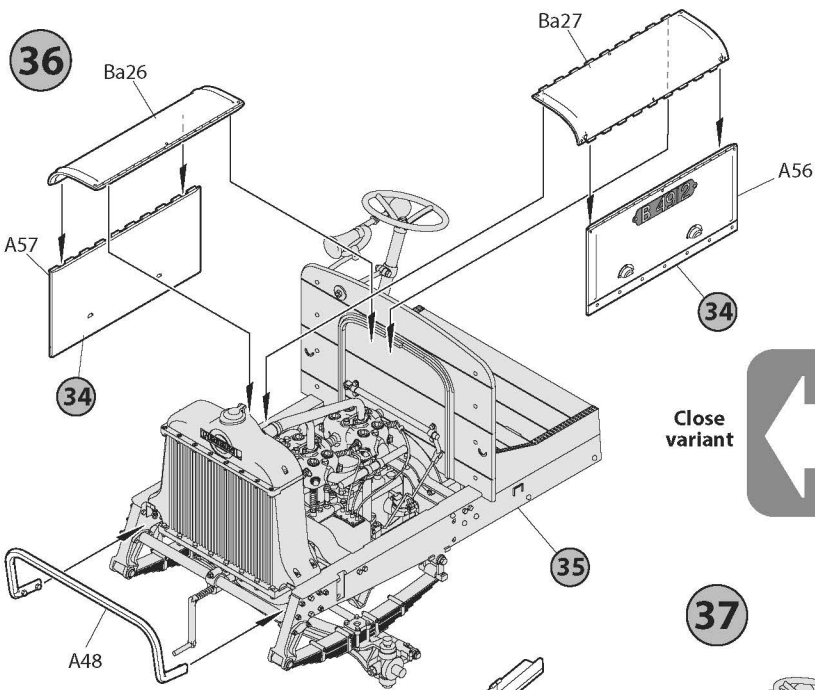

Close variant



Open variant

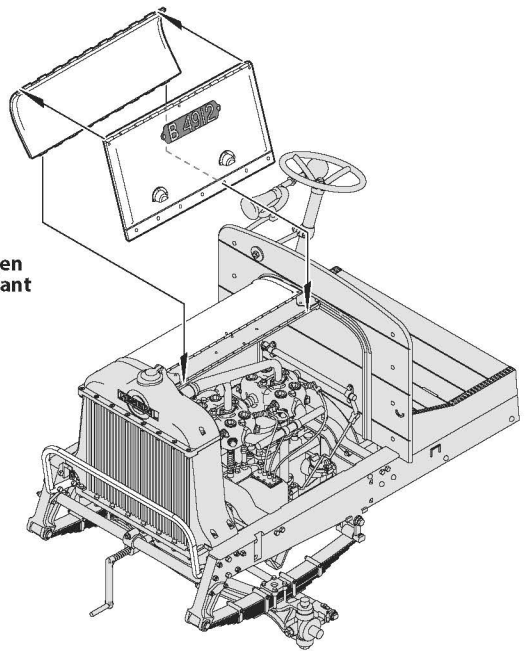

37

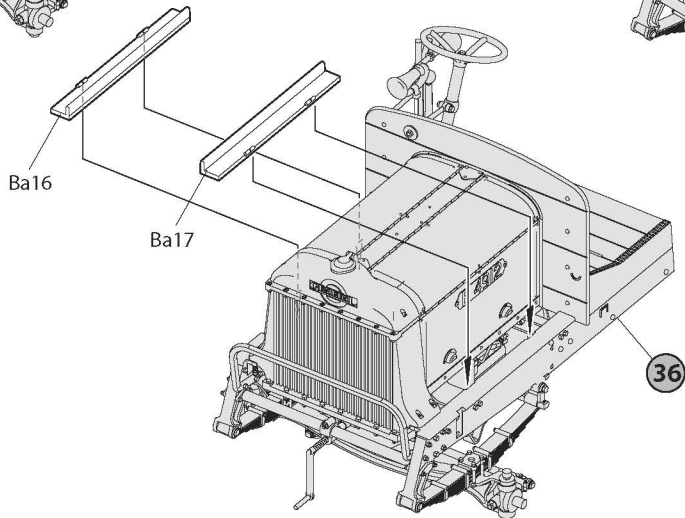

38

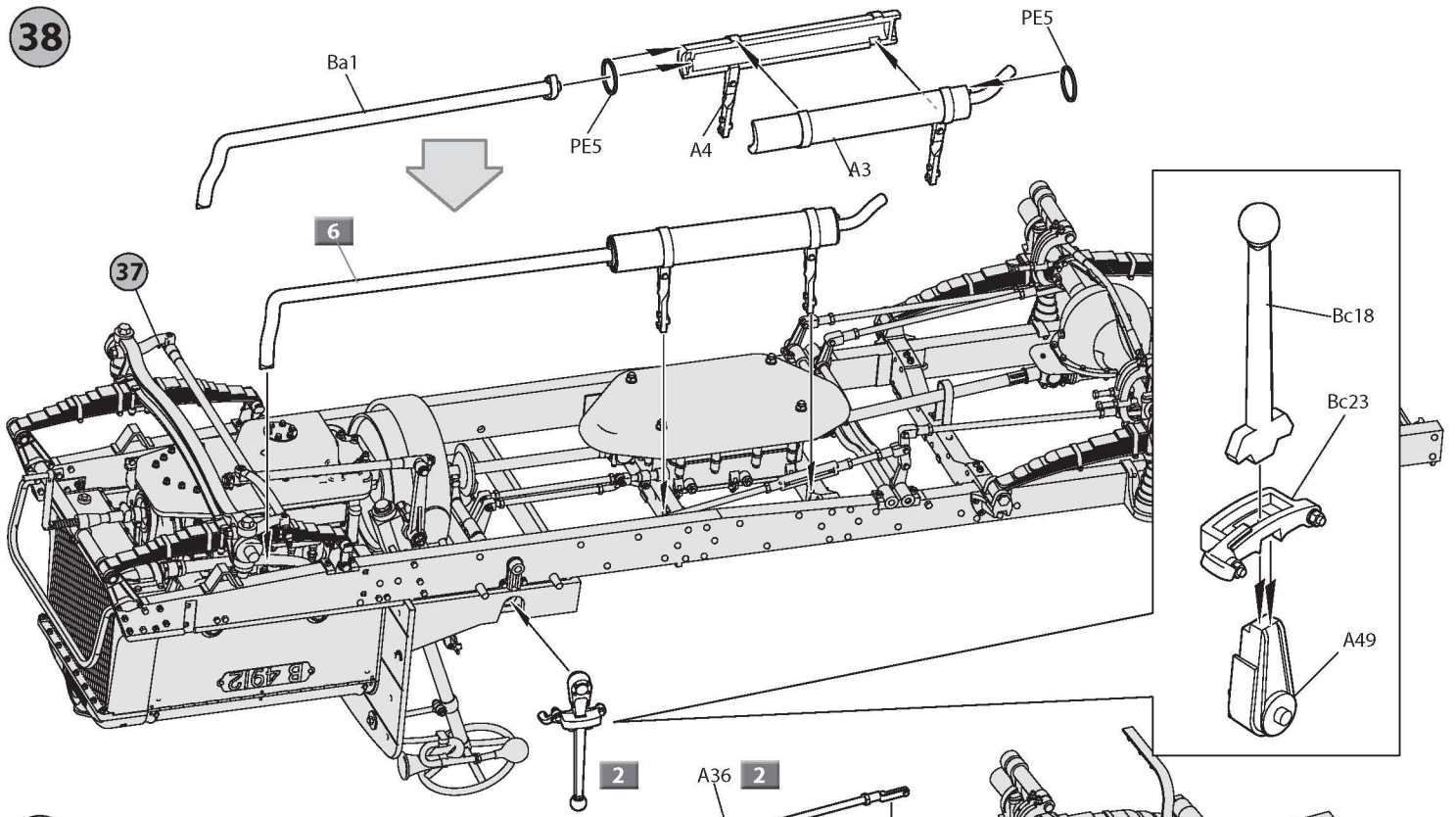

39

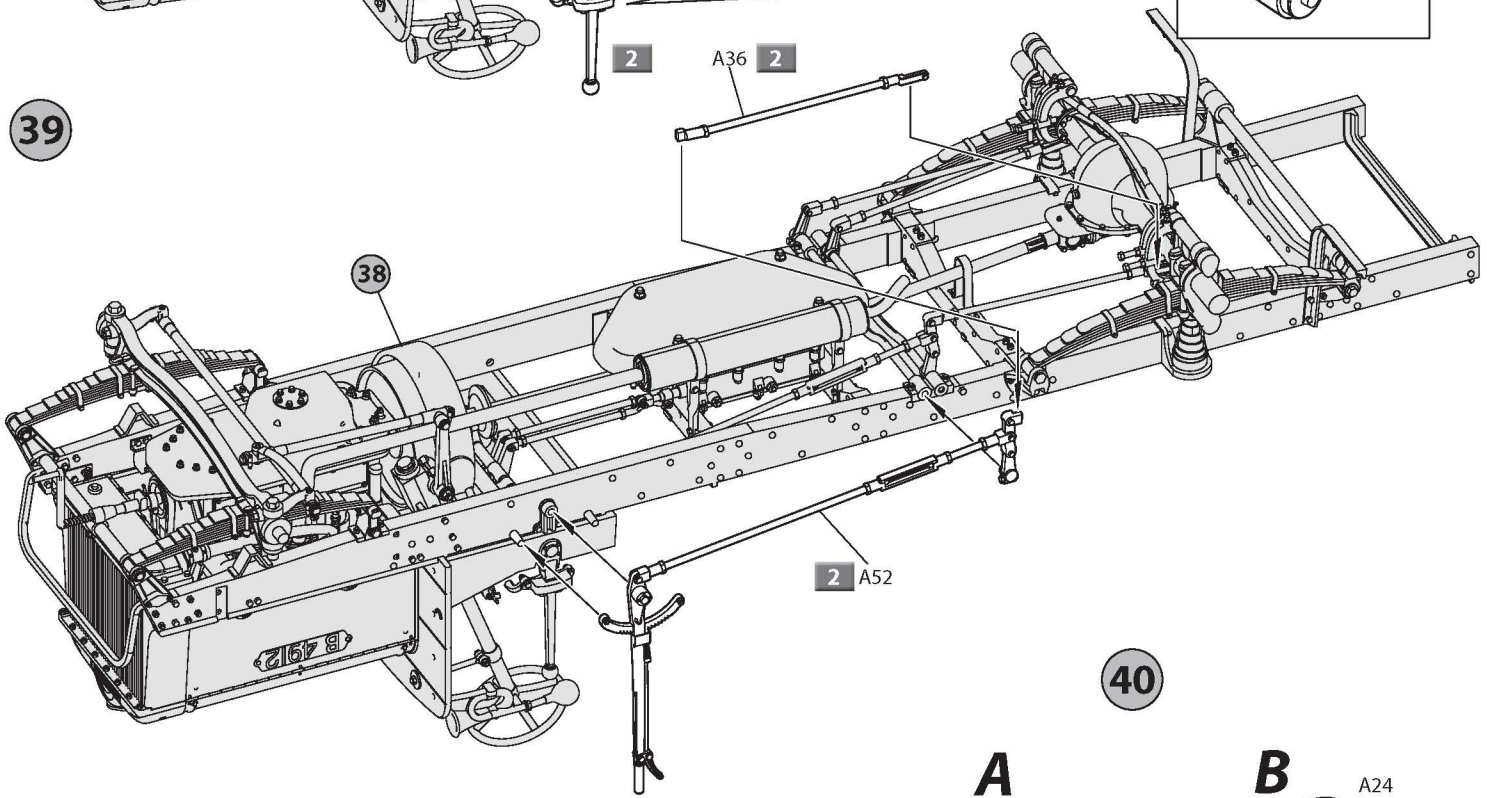

41

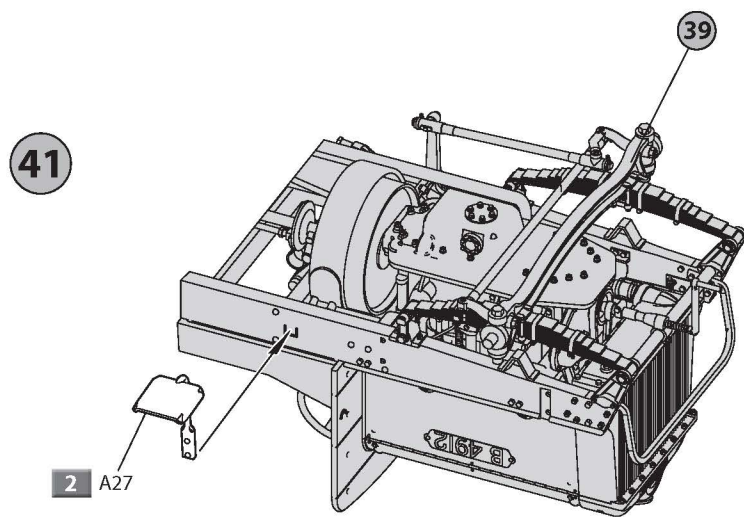

40

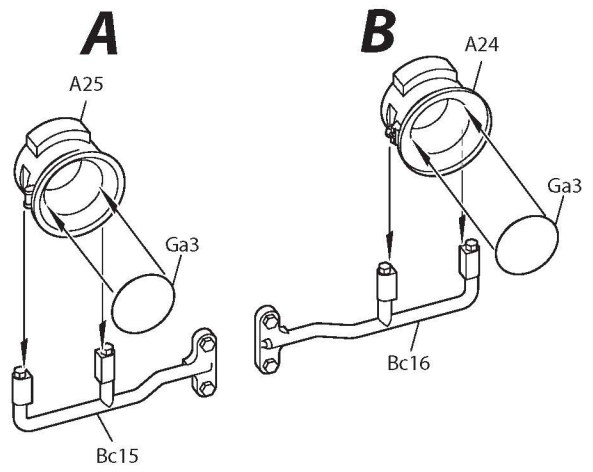

42

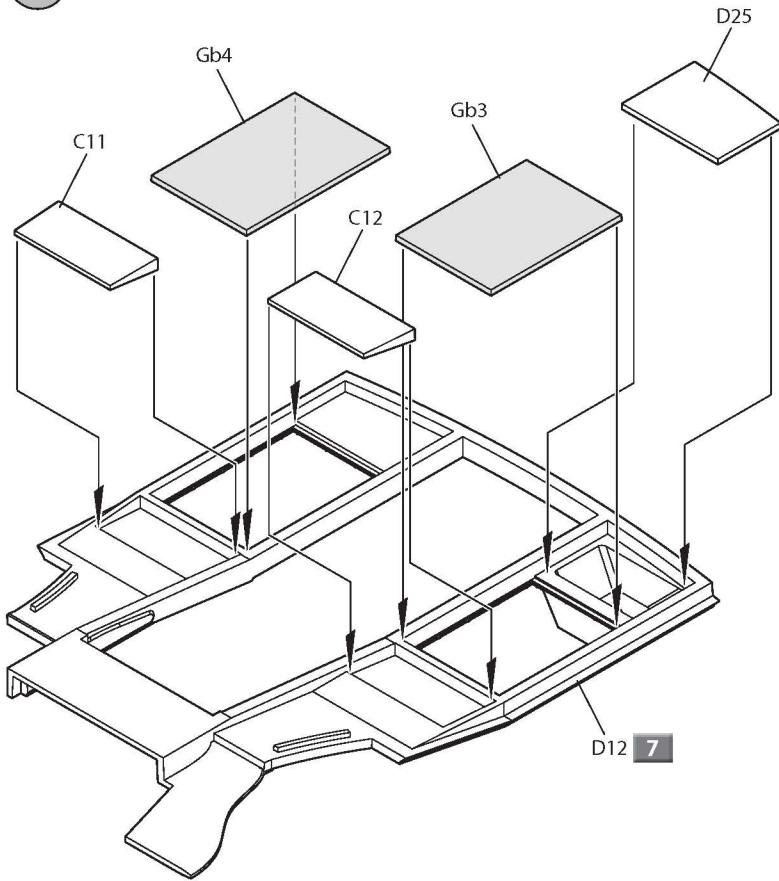

43

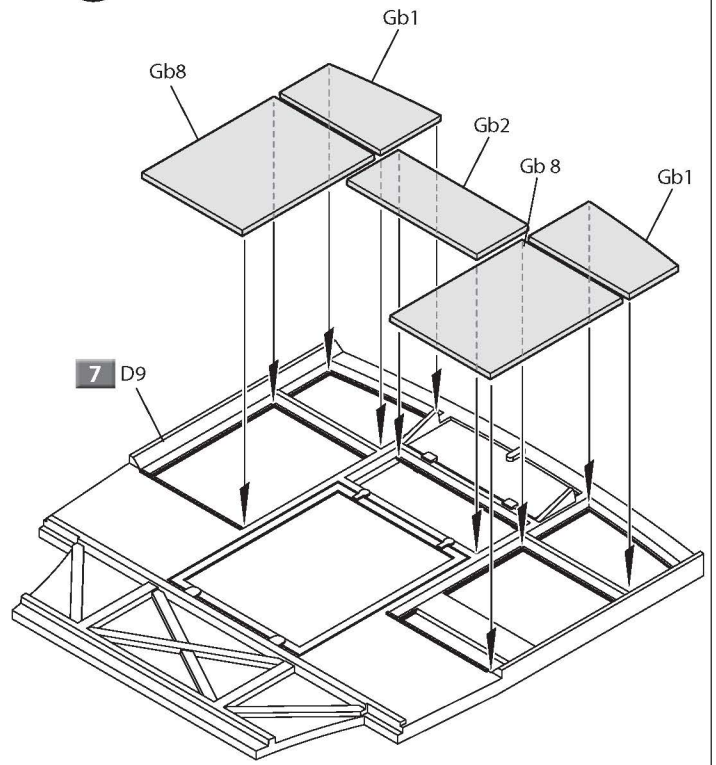

44

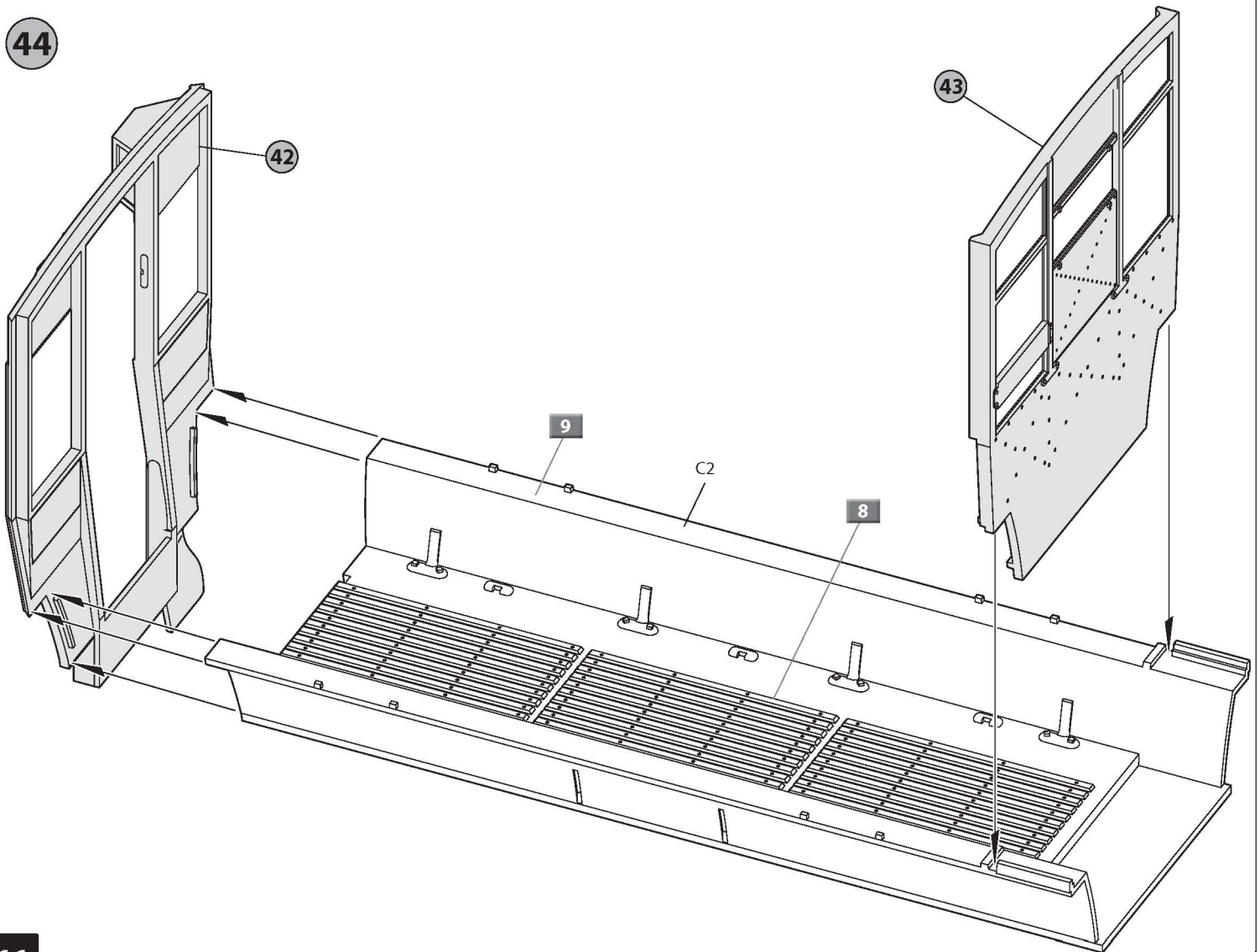

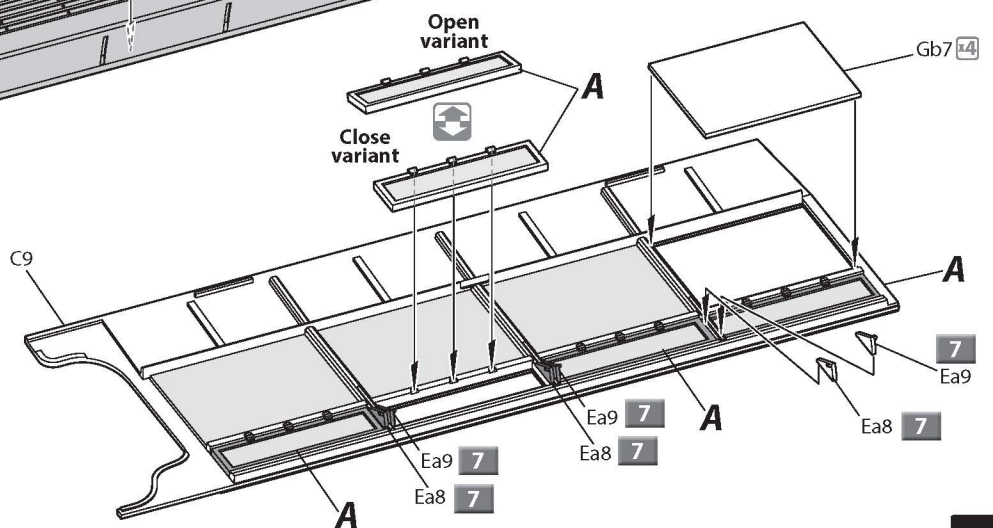
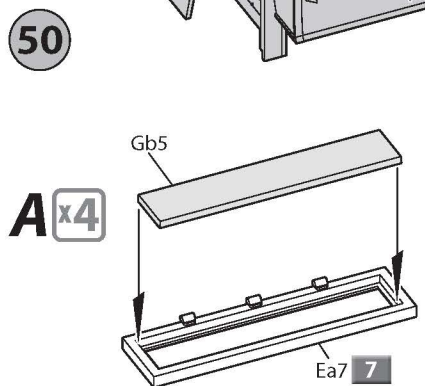
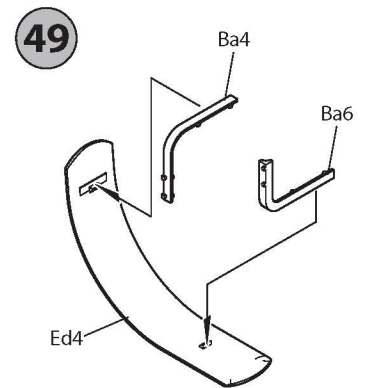
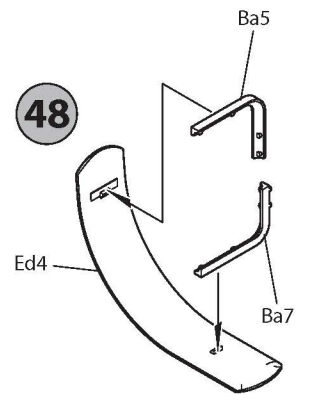
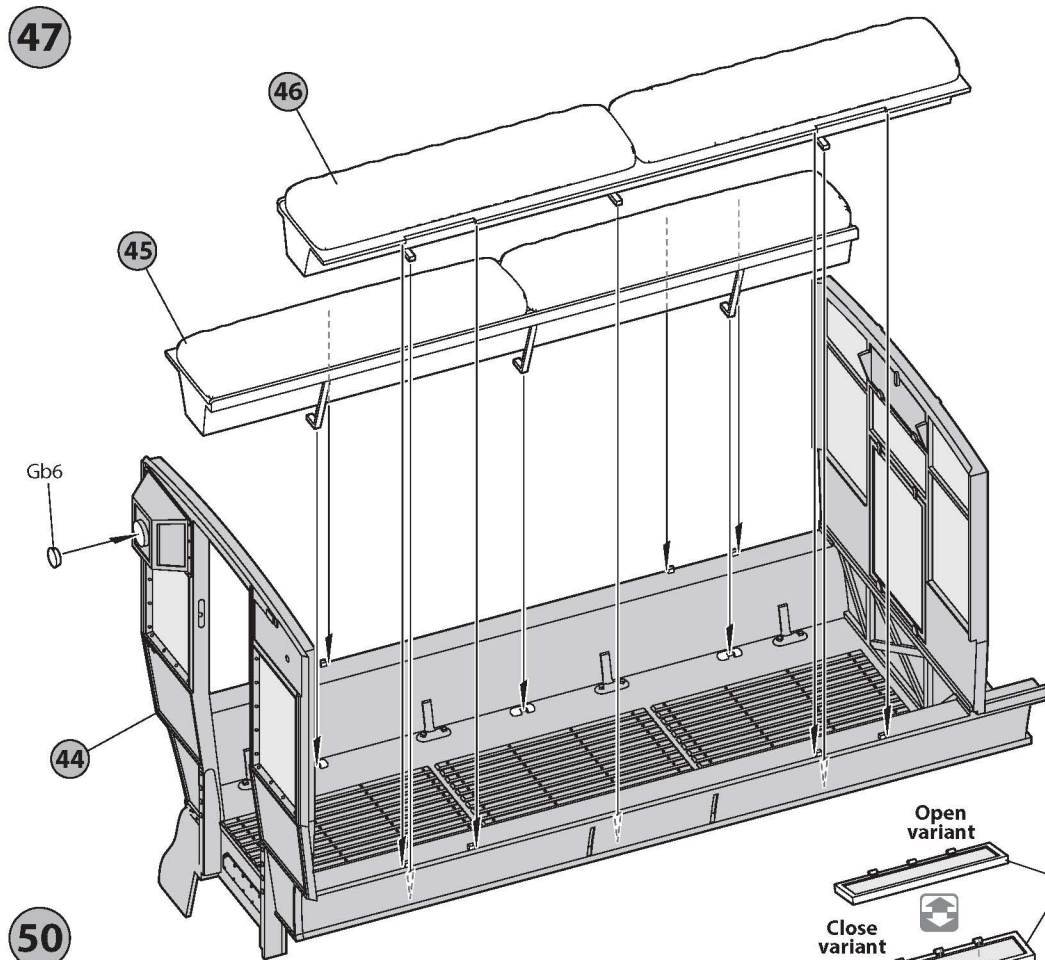
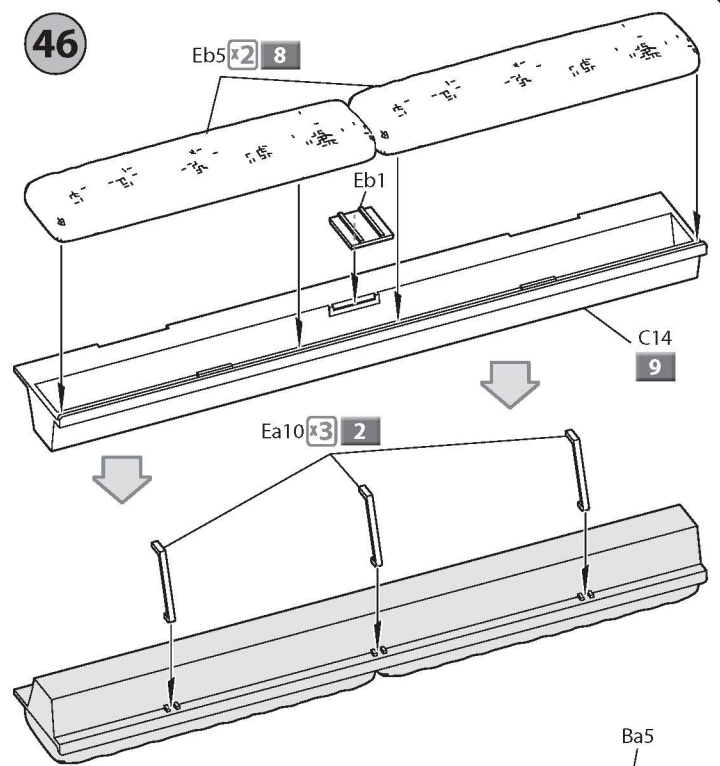
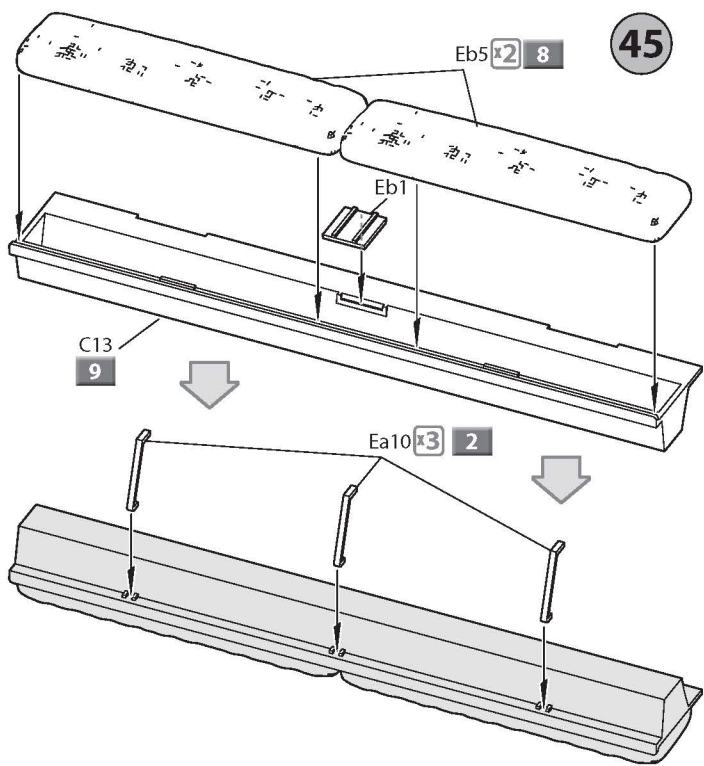

51

A x4

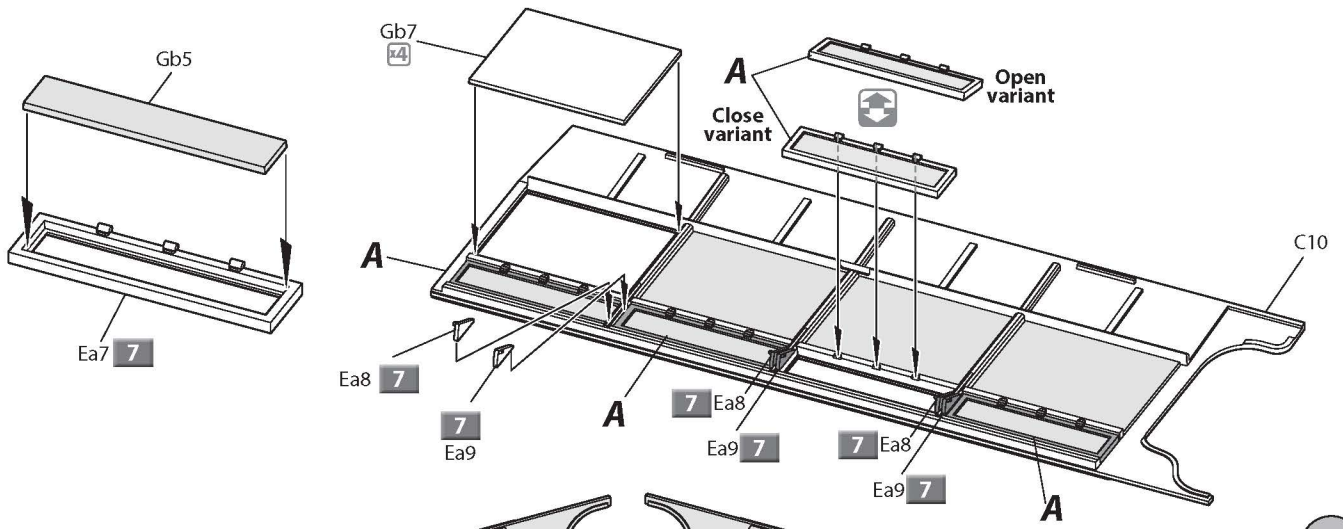

52

50

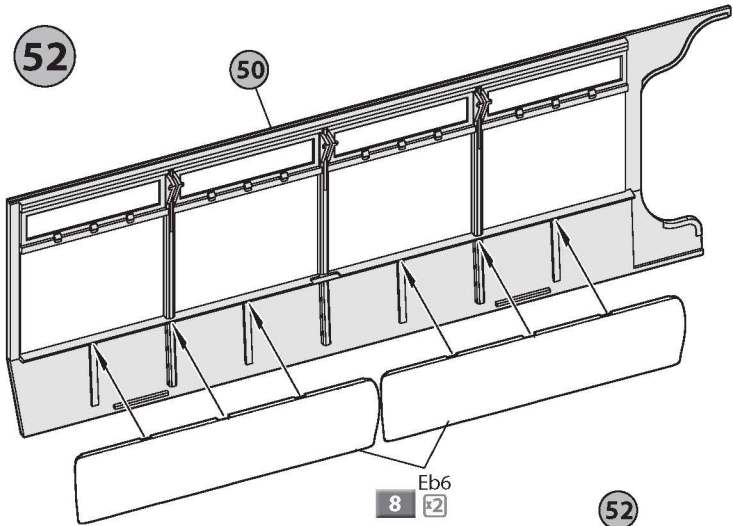

8 Eb6

53

51

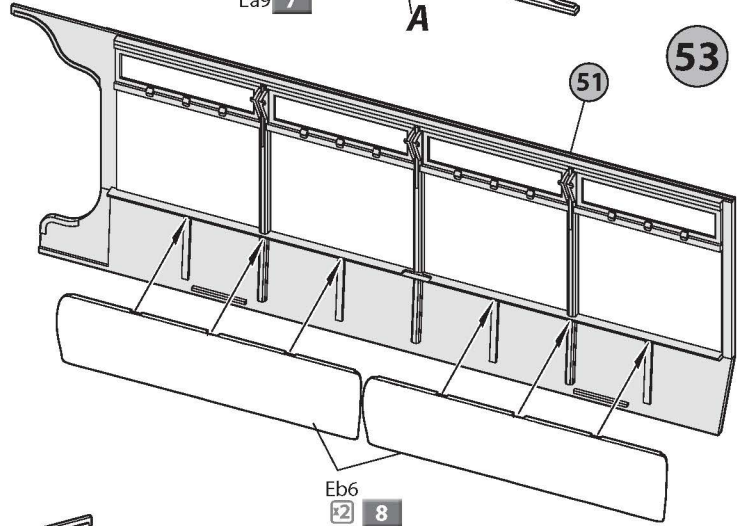

54

47

53

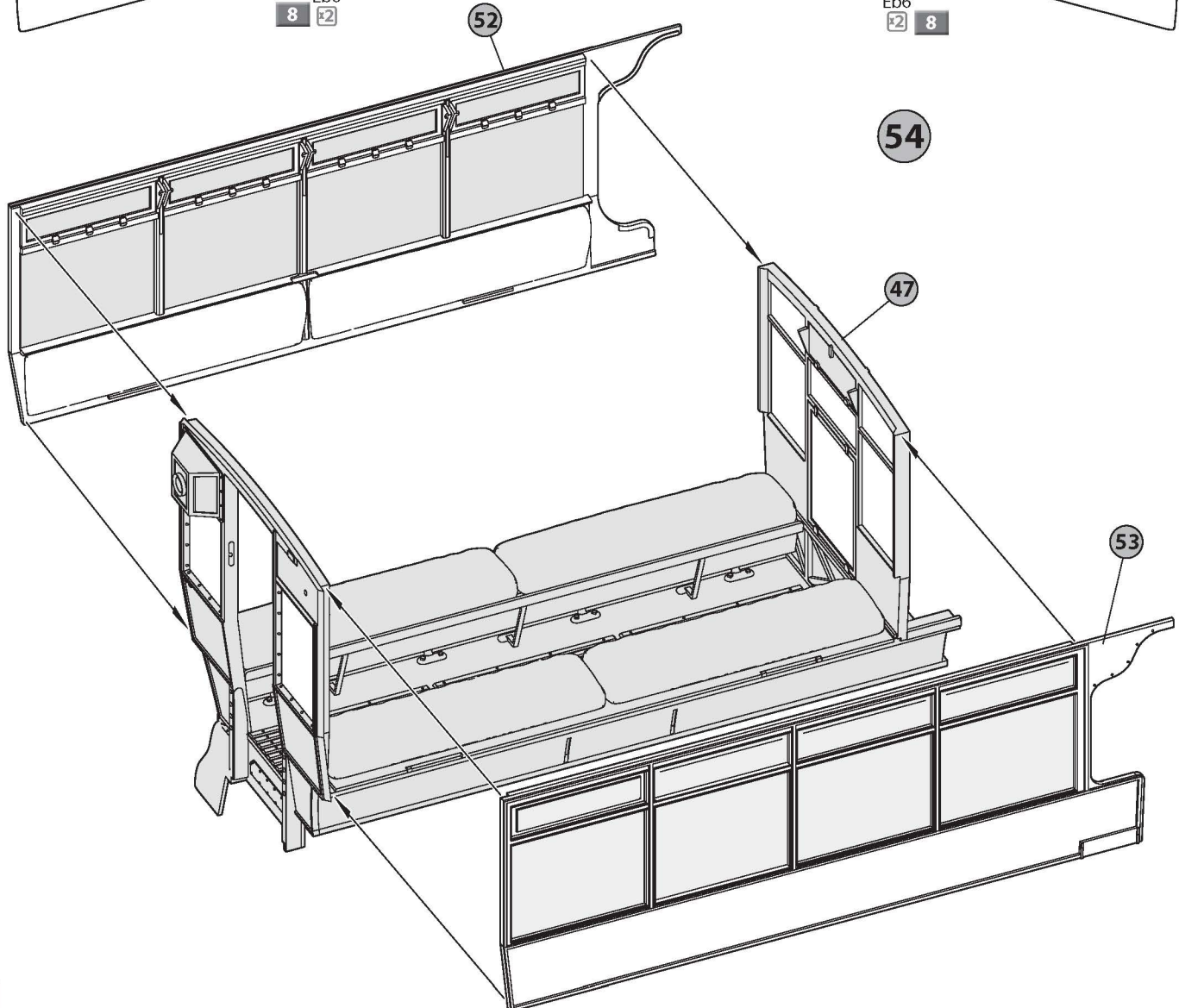

55 x2

Repeat on the reverse side

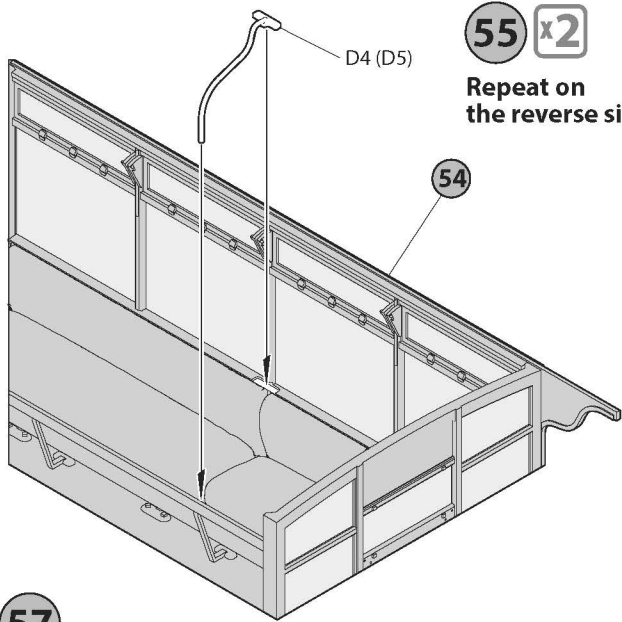

56

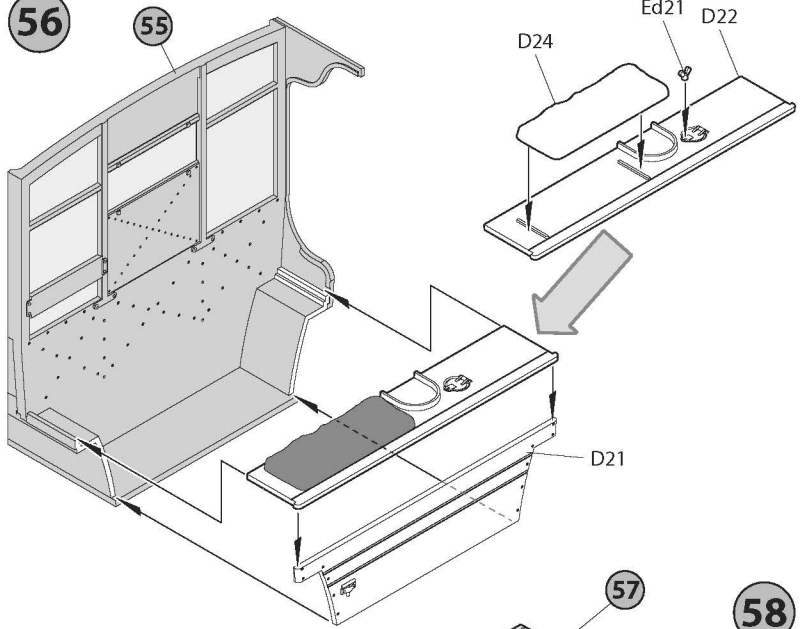

57

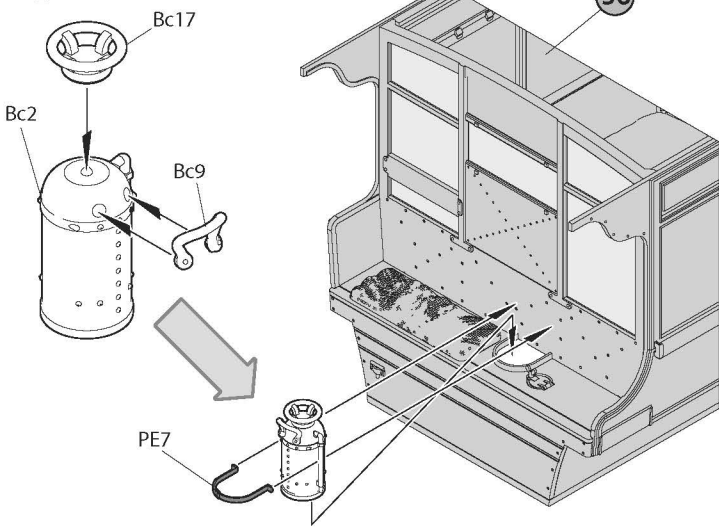

58

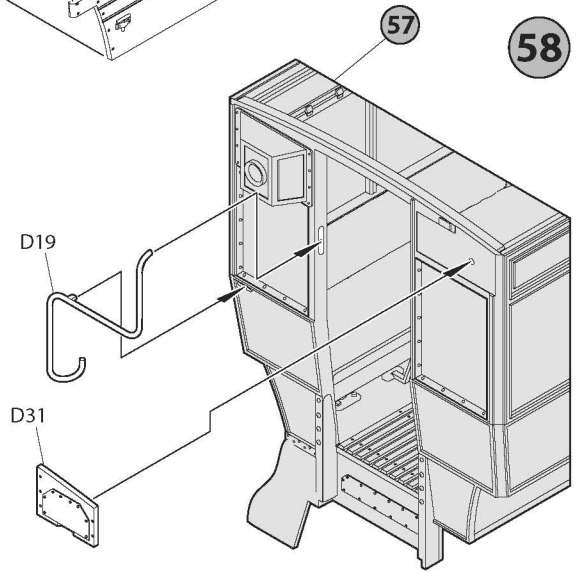

60

x2 Repeat on the reverse side

59

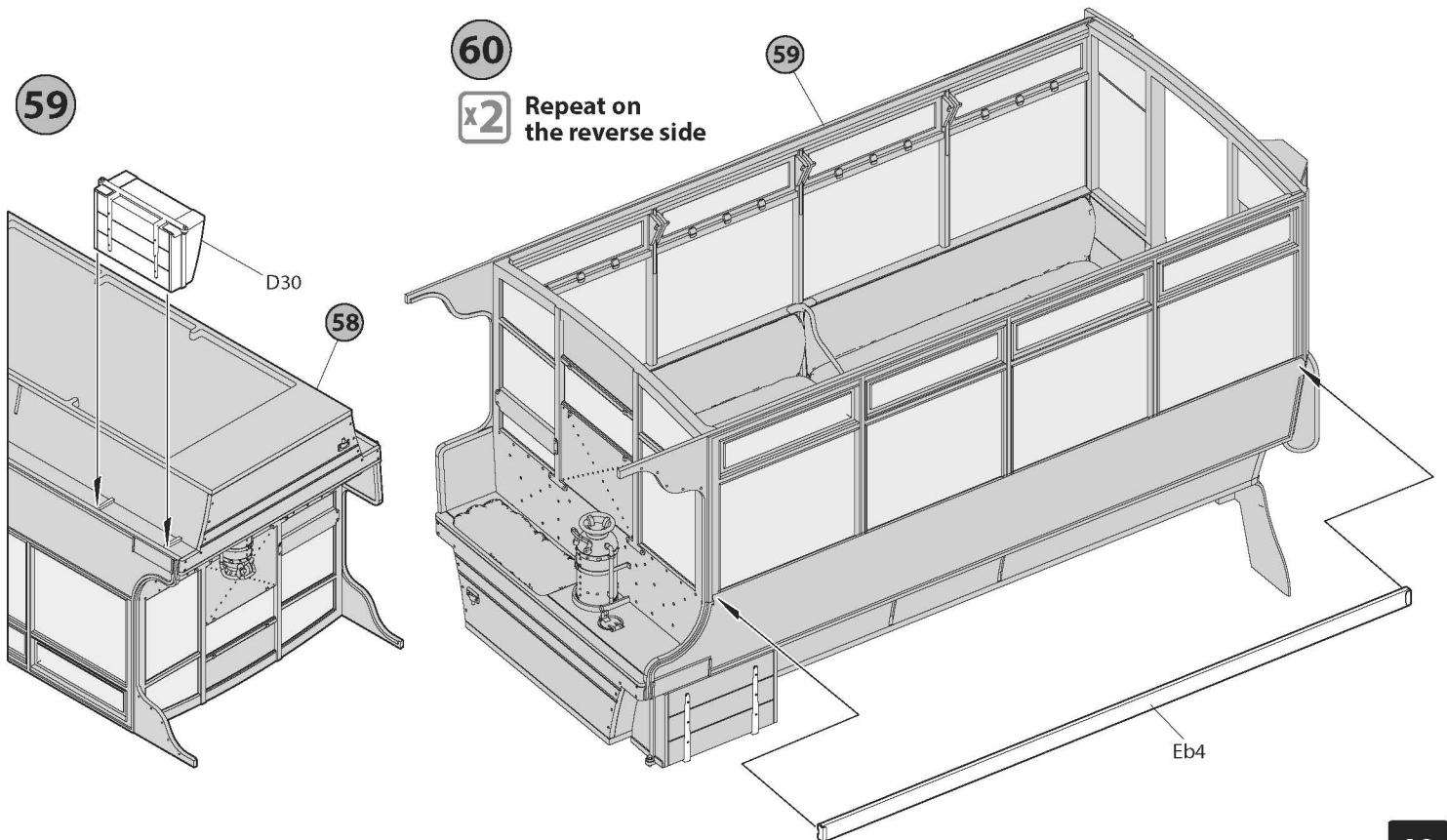

59

Eb4

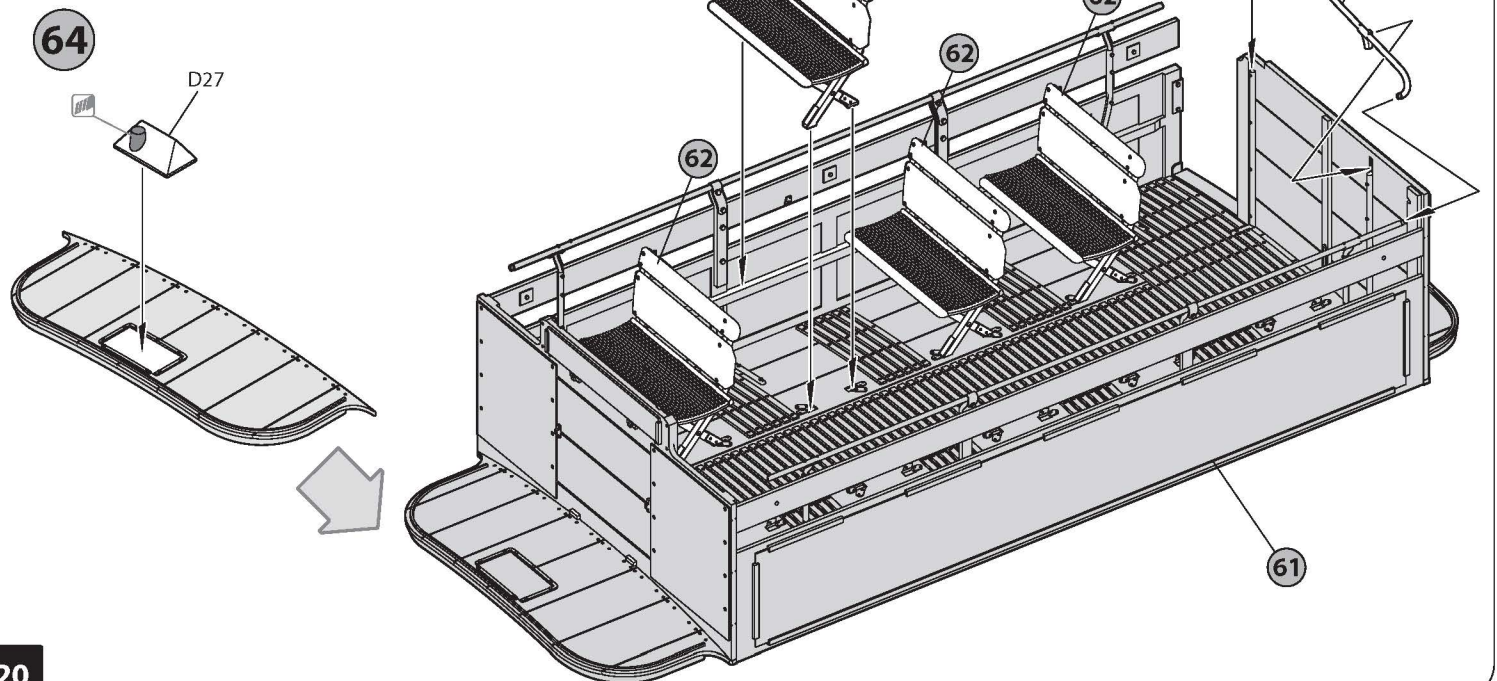
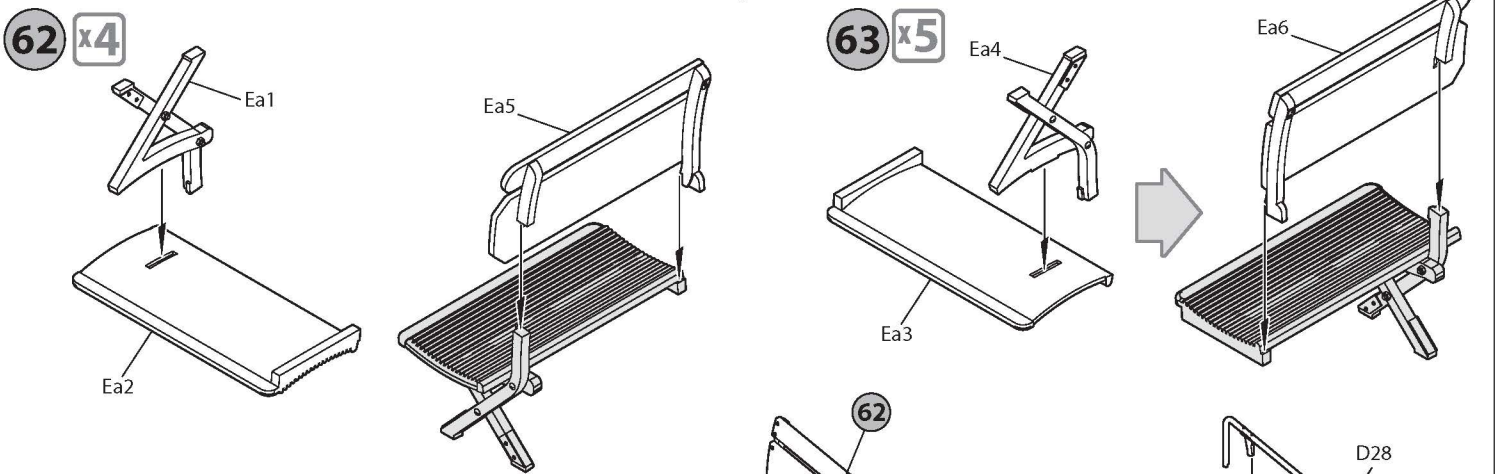
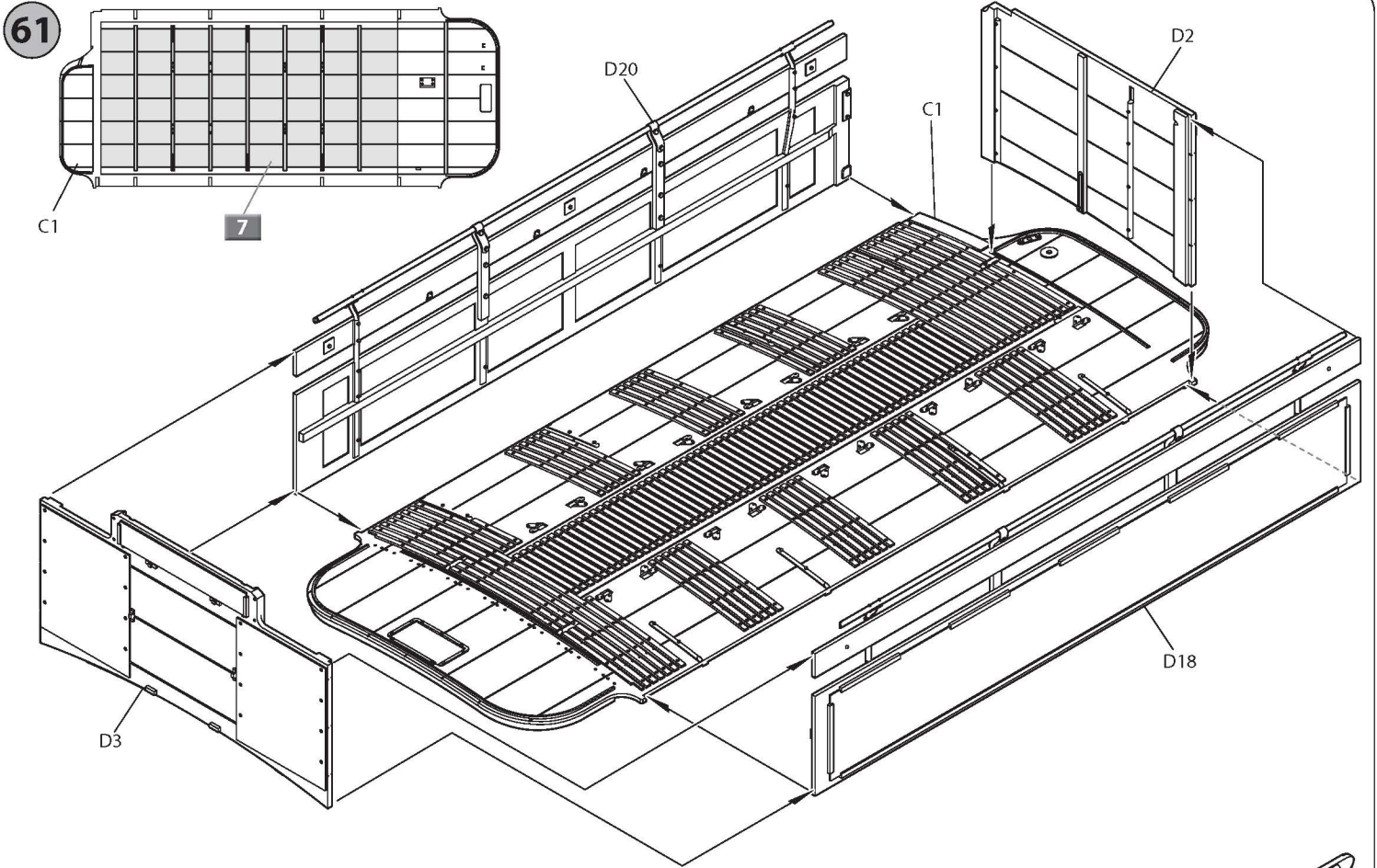

65

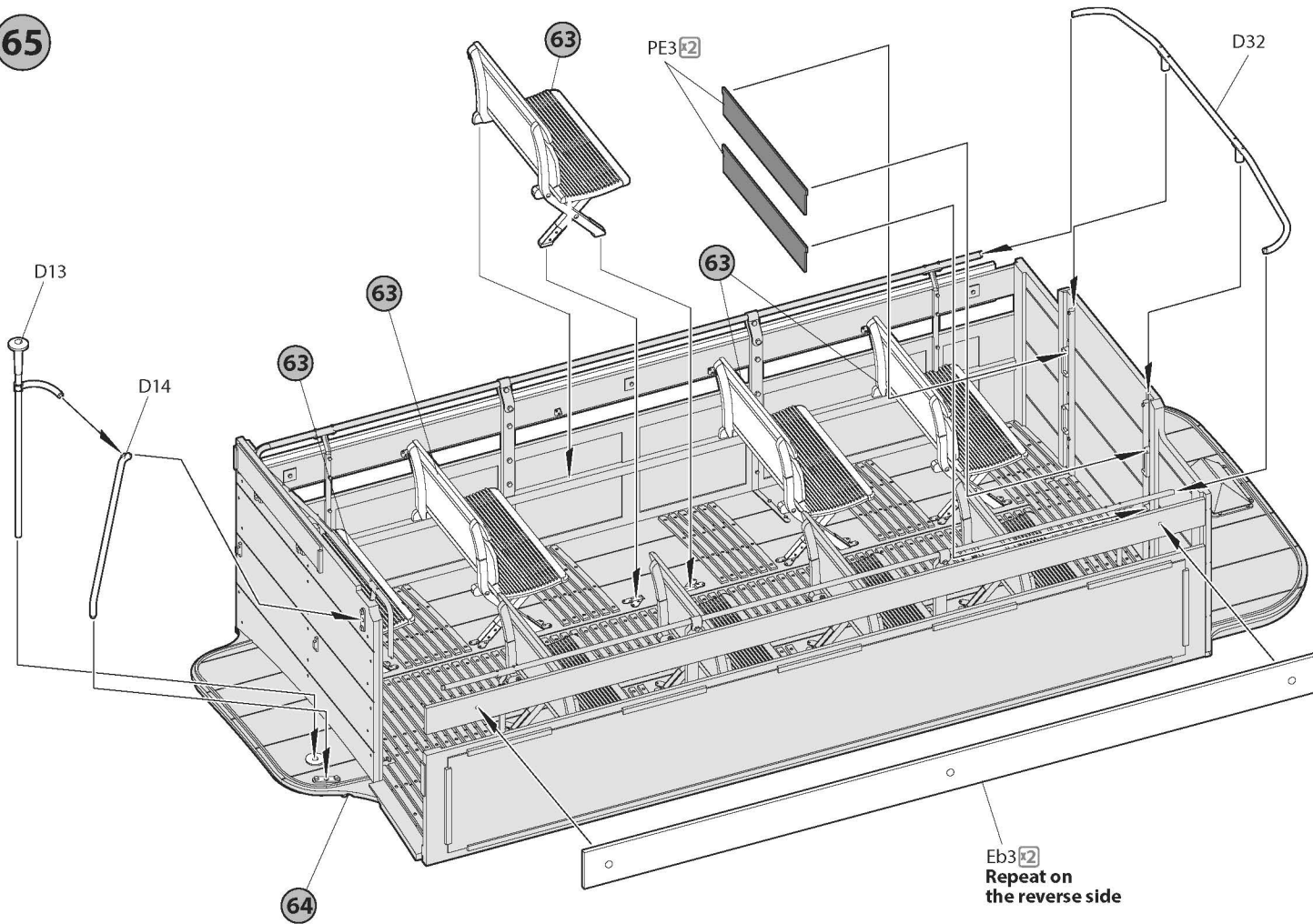

66

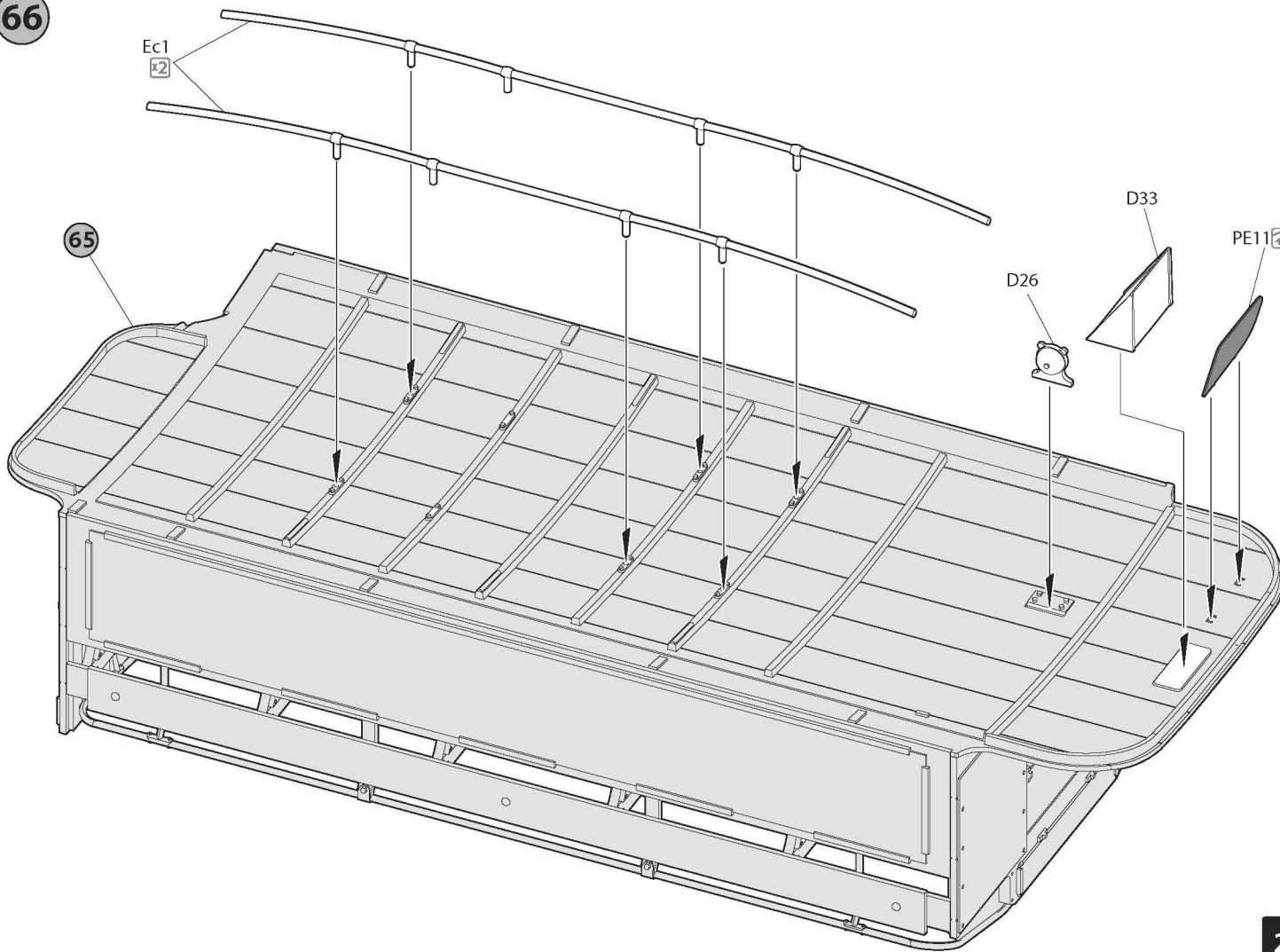

67

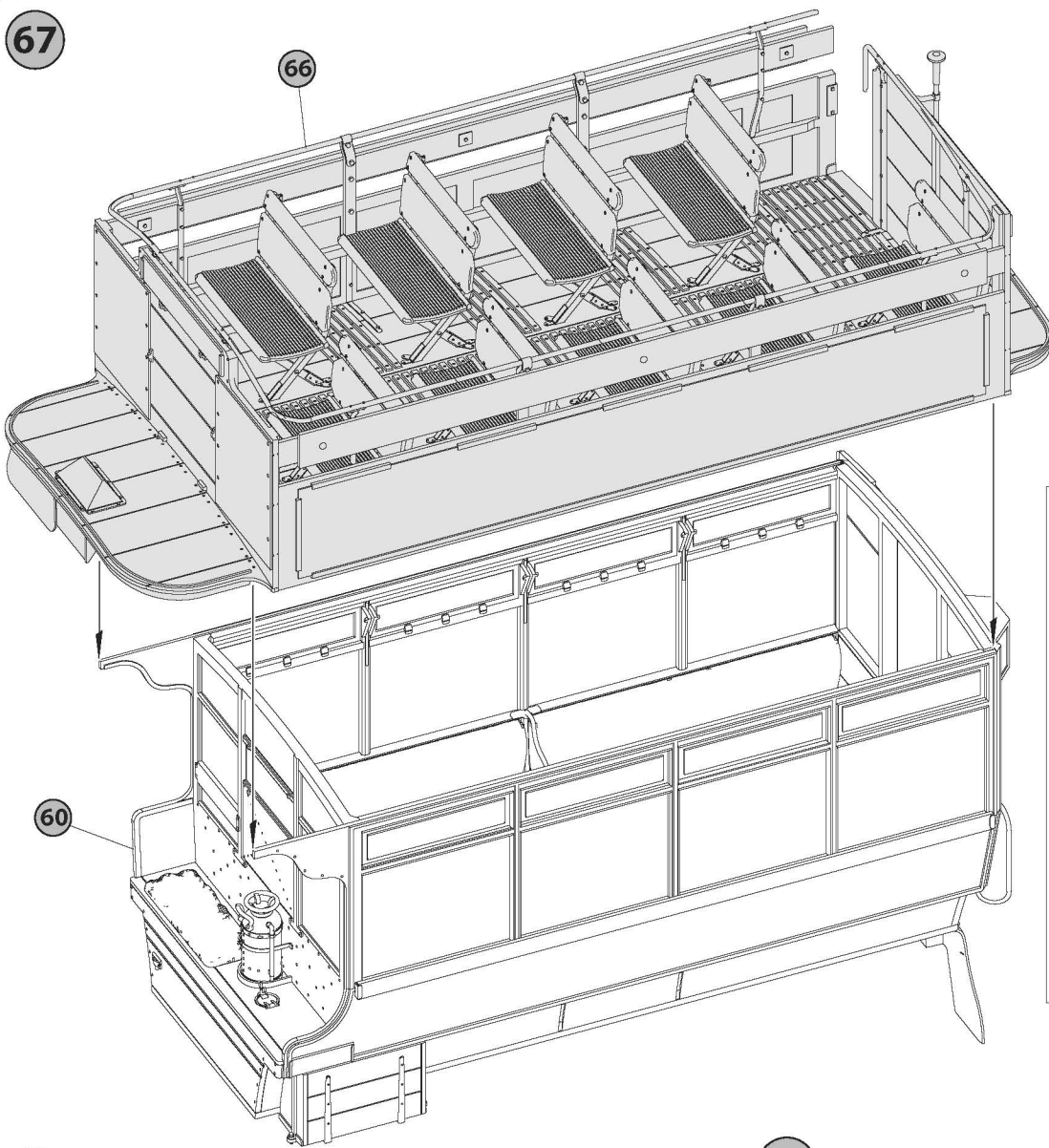

68

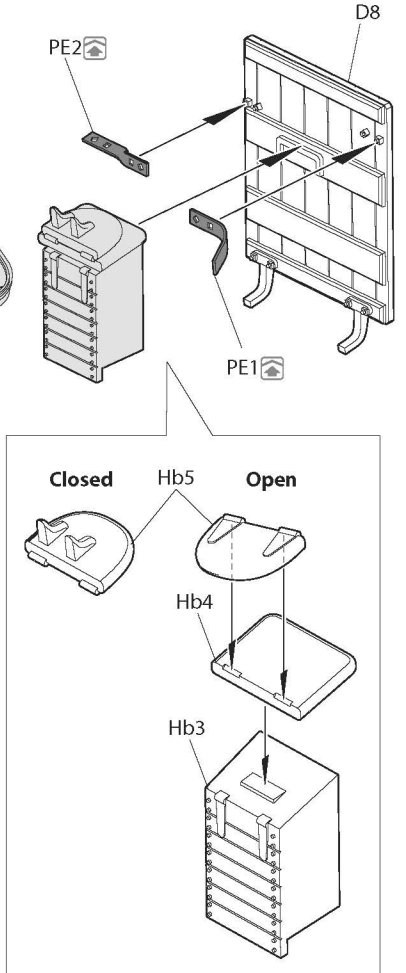

69

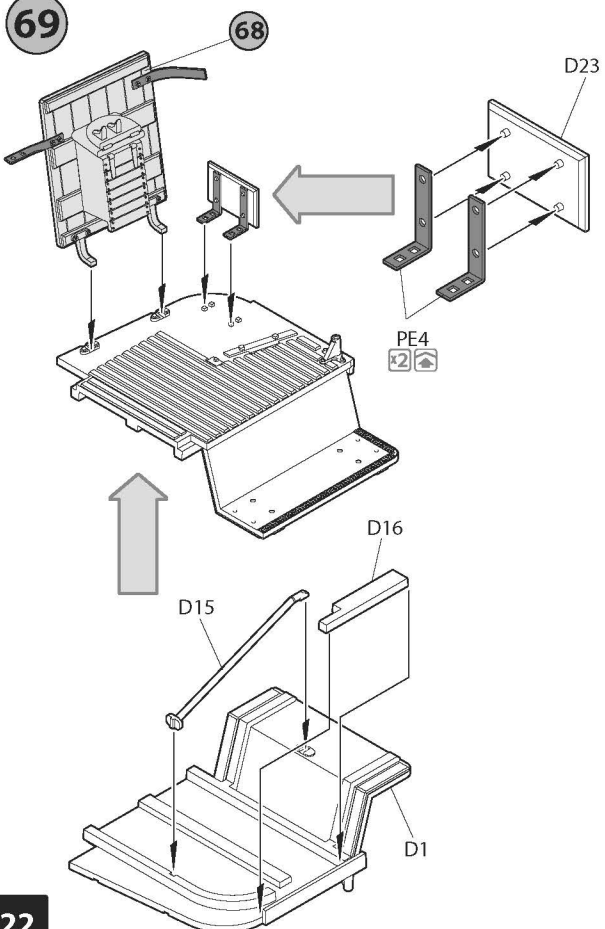

70

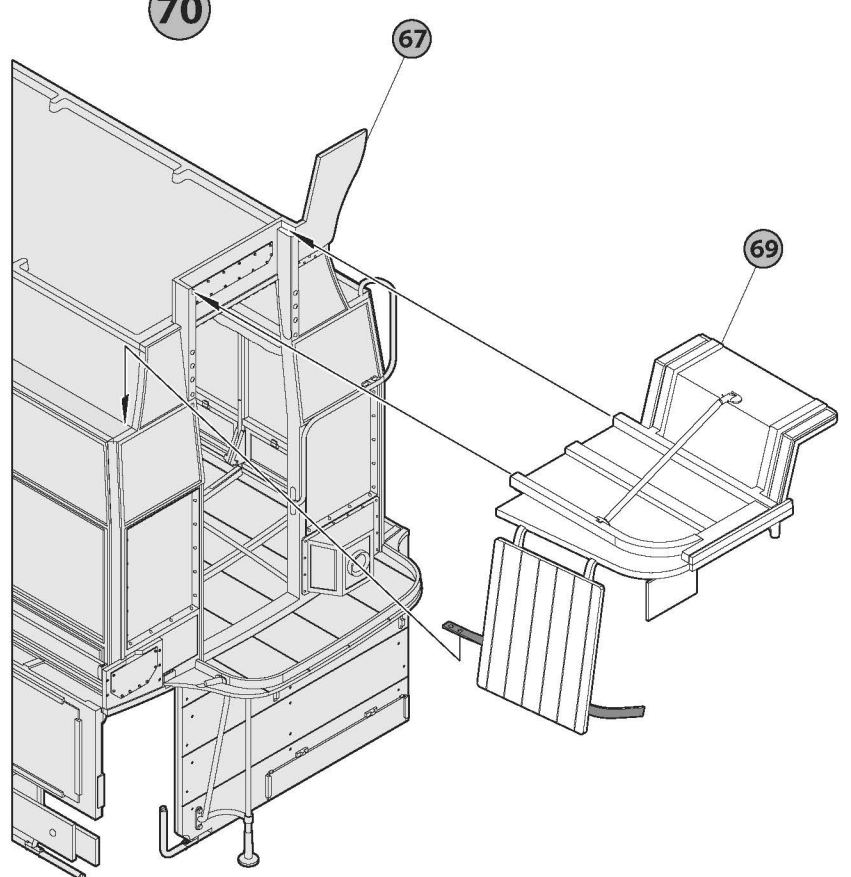

71

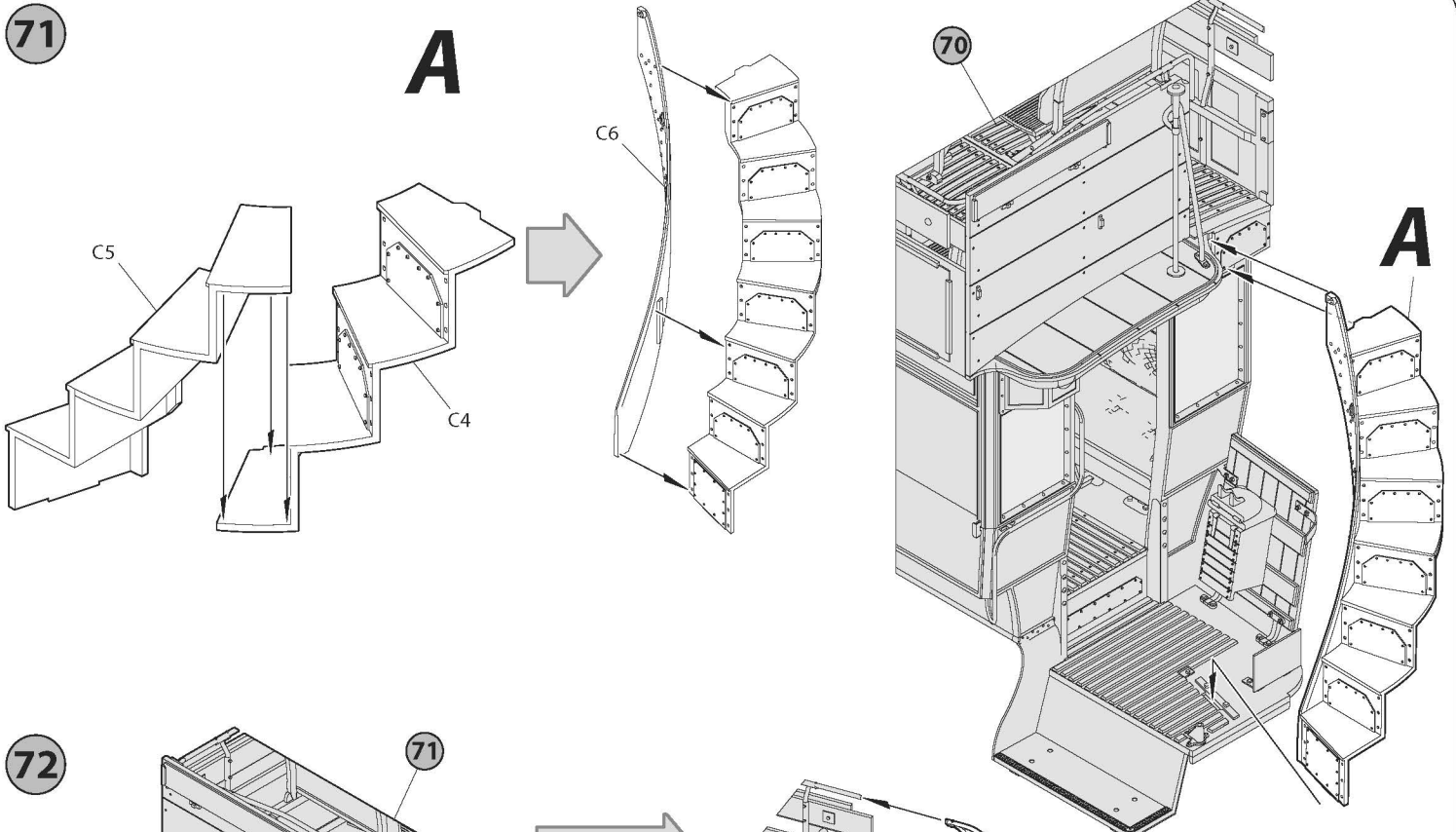

72

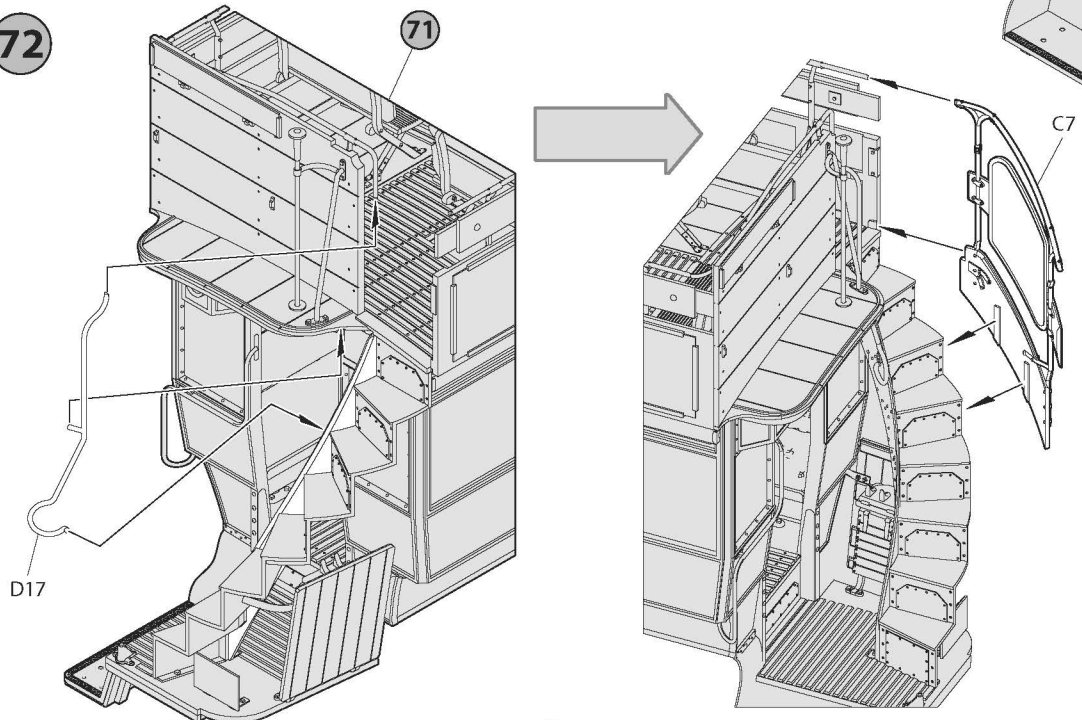

73

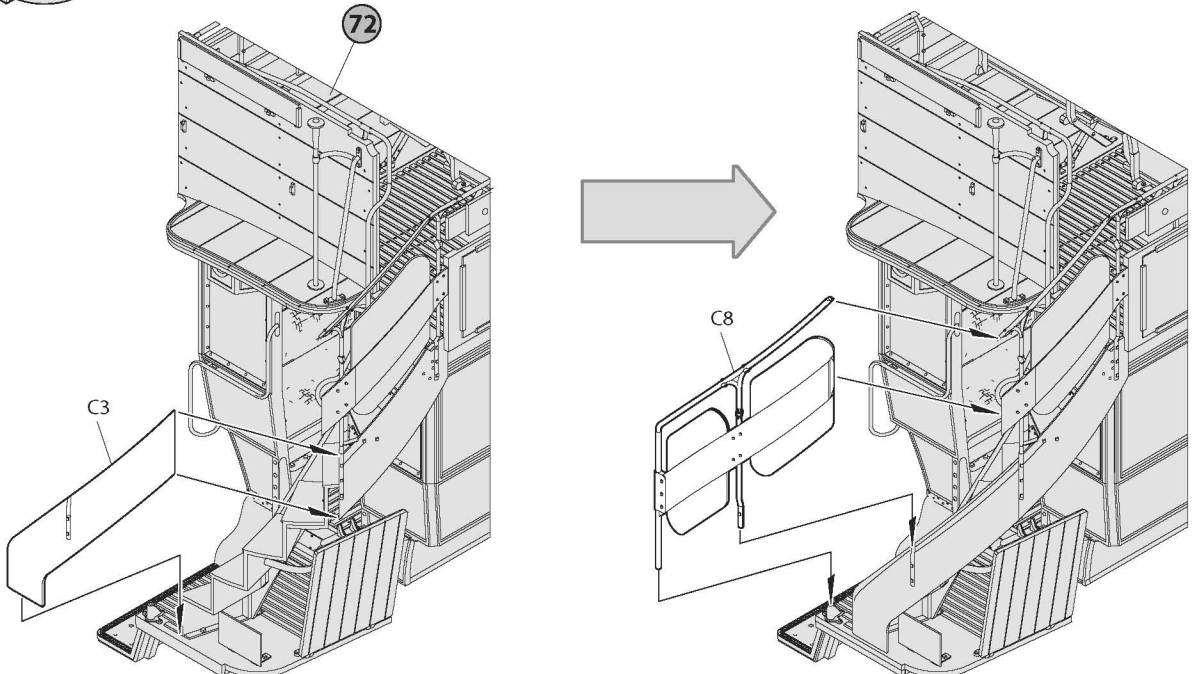

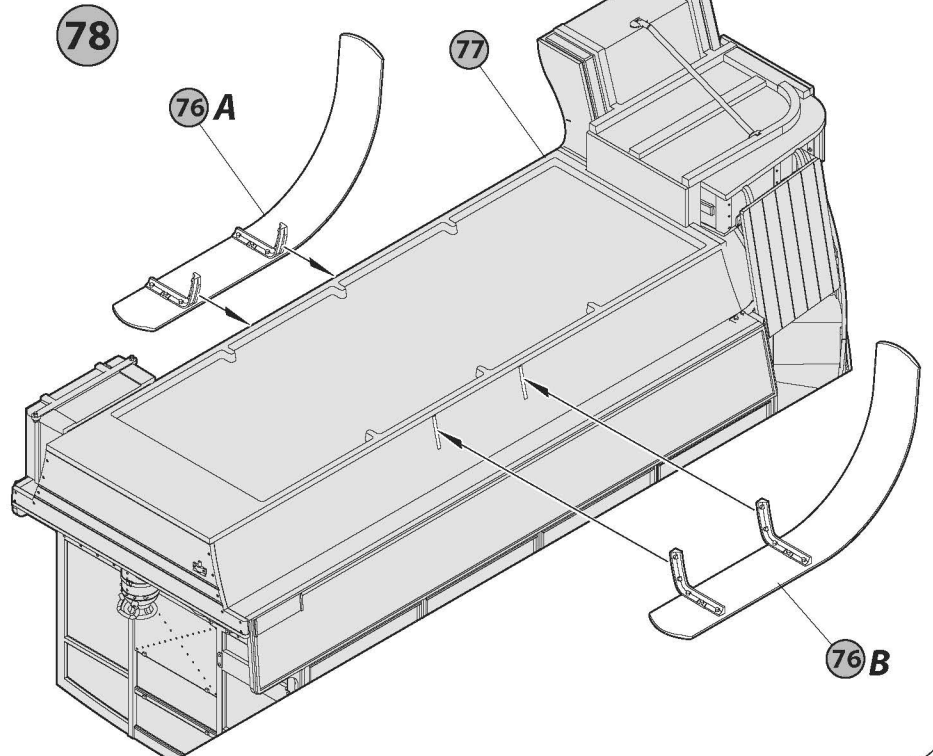
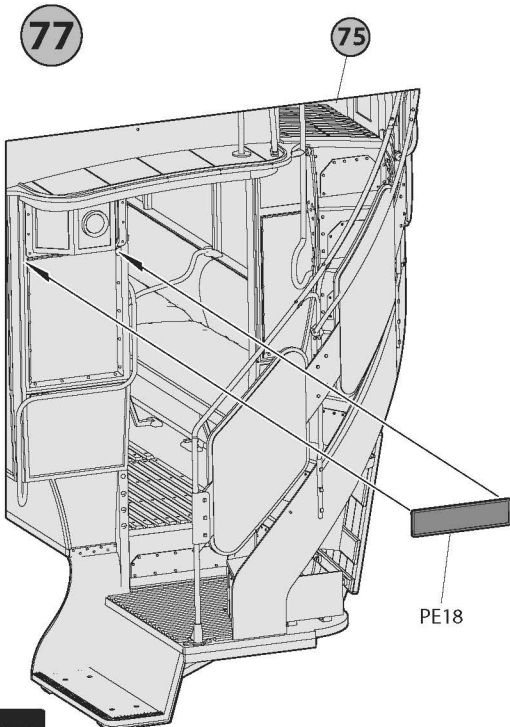
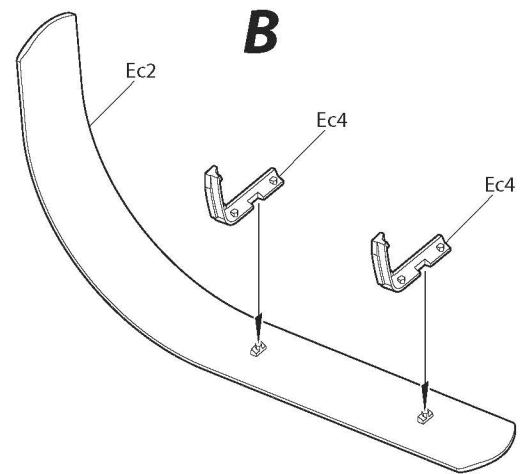
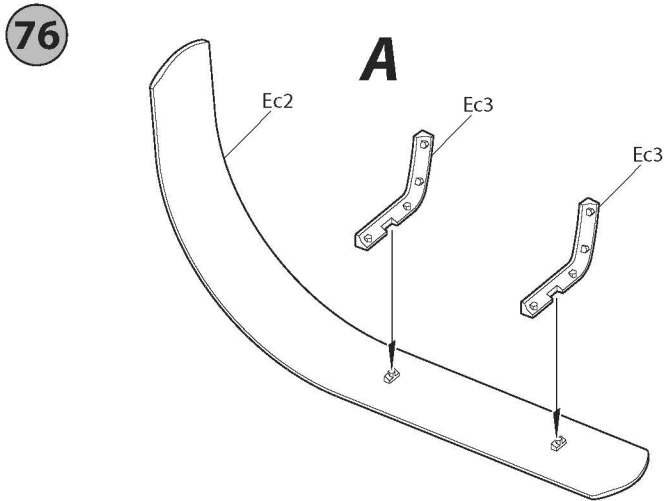
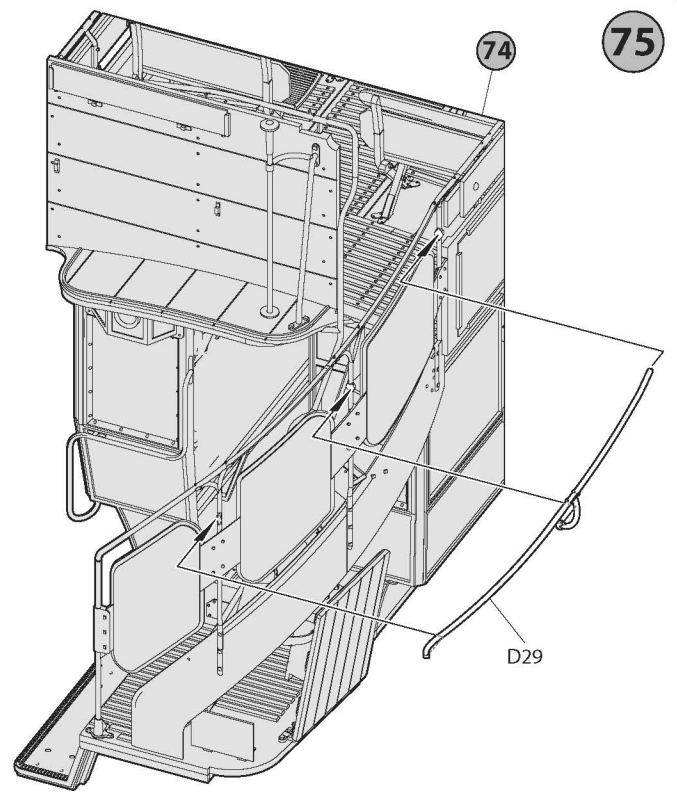
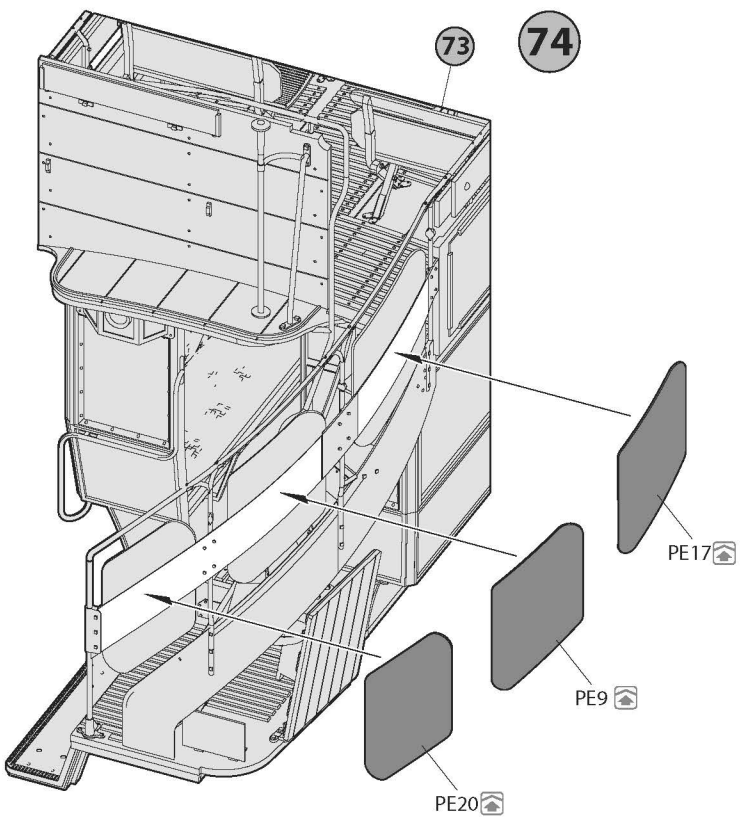

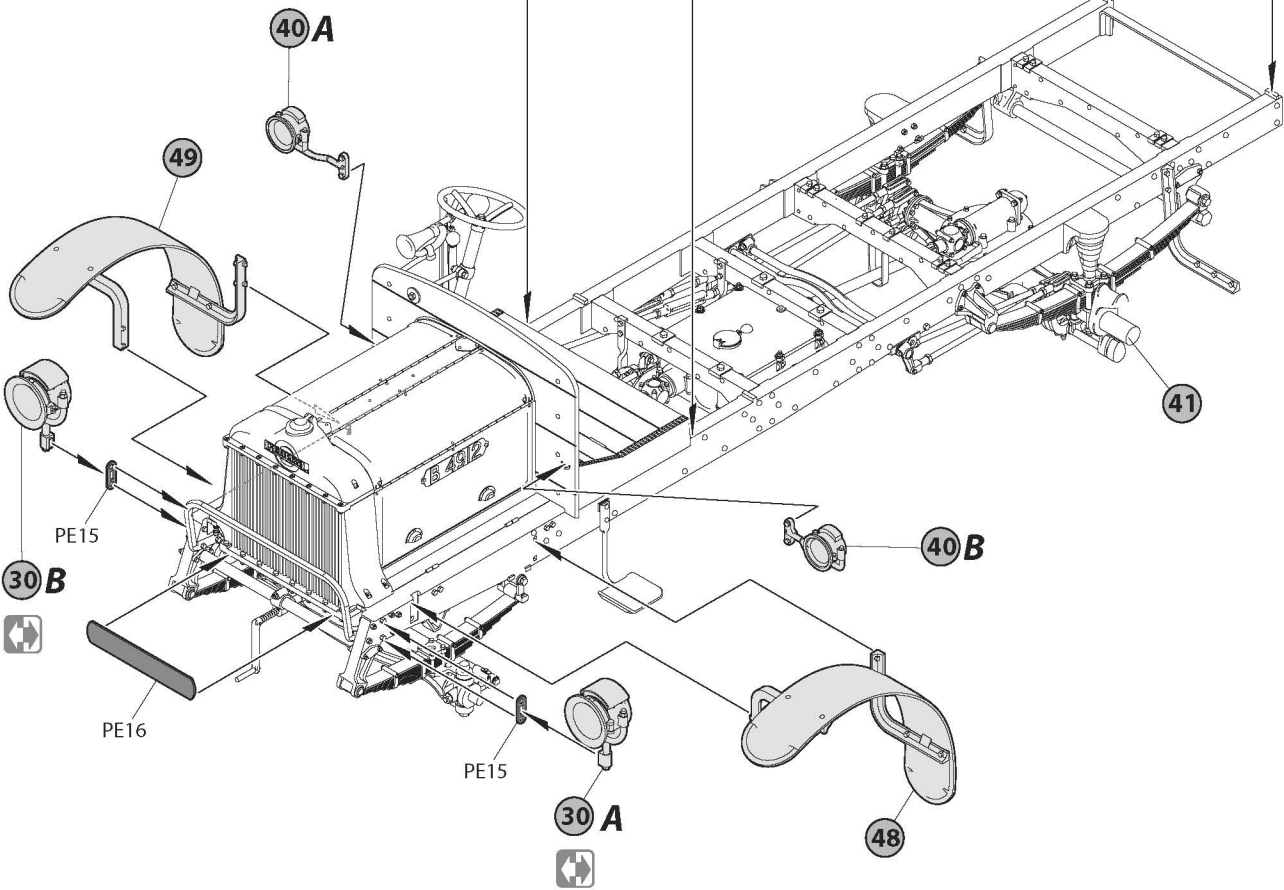
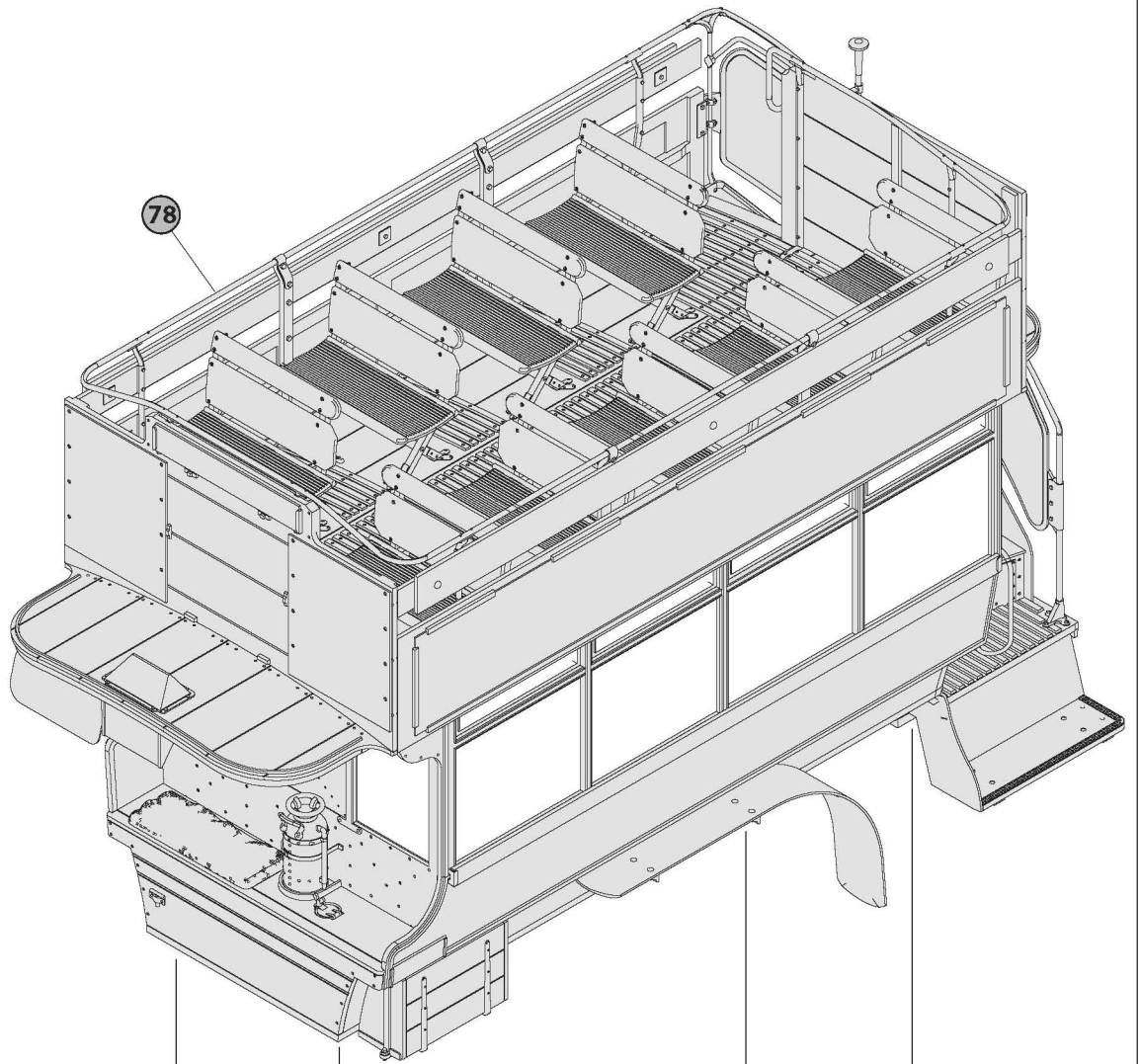

80

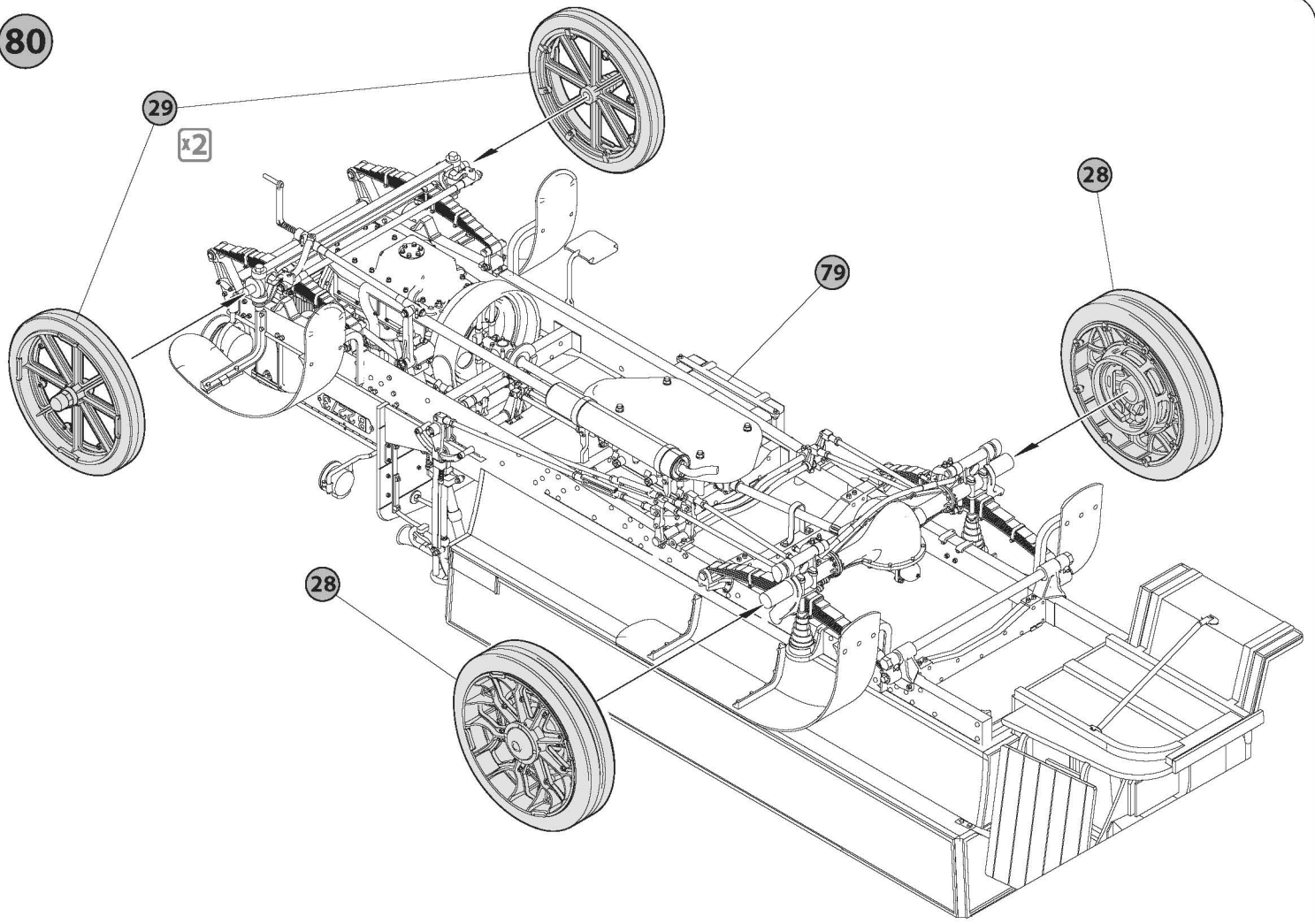

81

Repeat on the reverse side

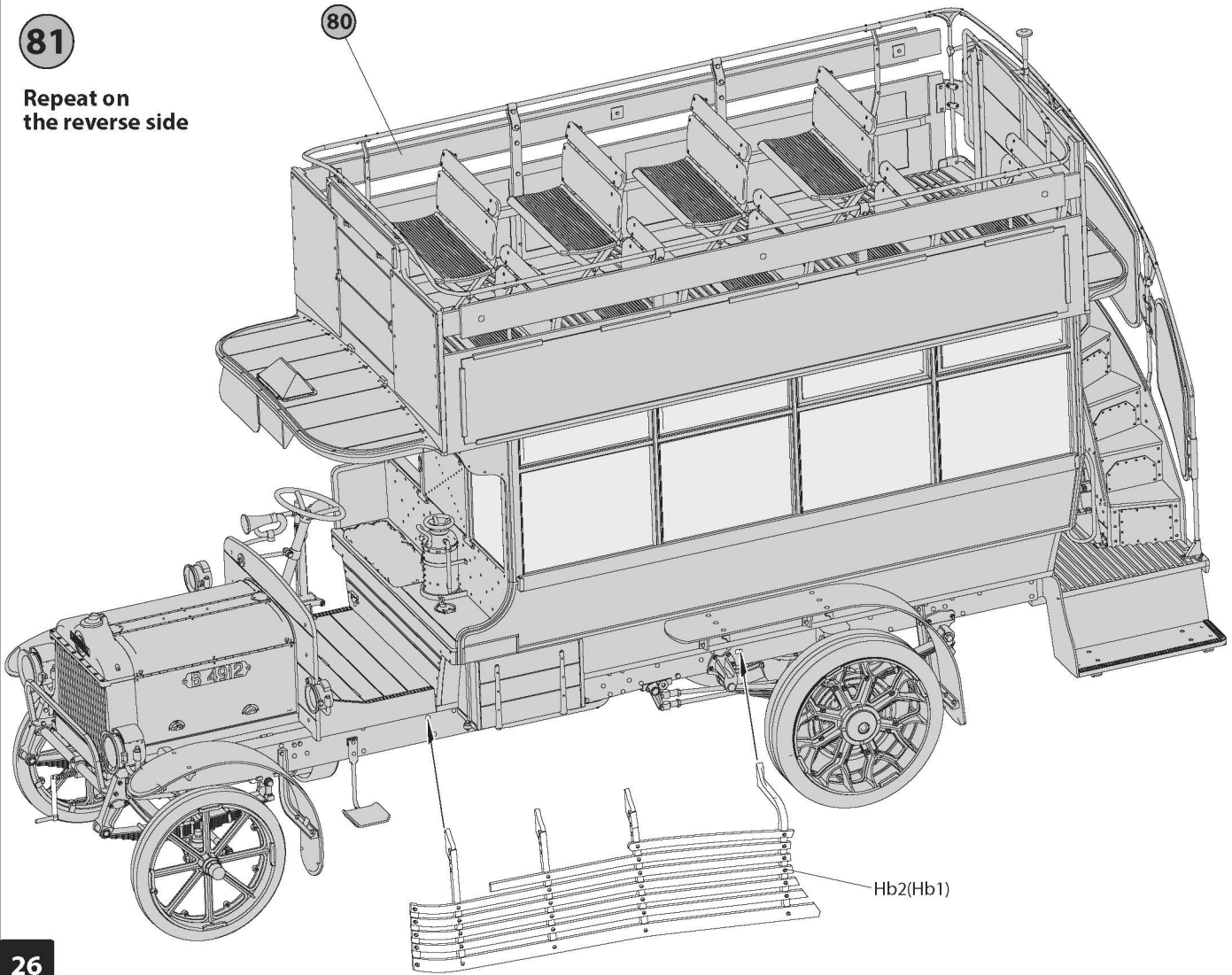

PAINTING GUIDE

3 London, 1920's.



PAINTING GUIDE

3 London, 1920's.

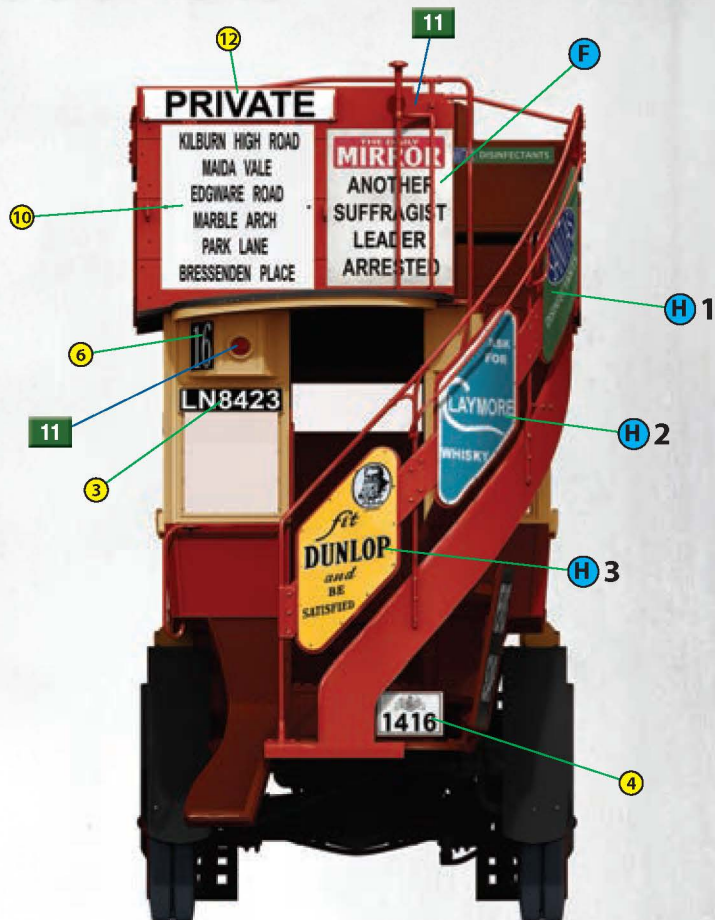
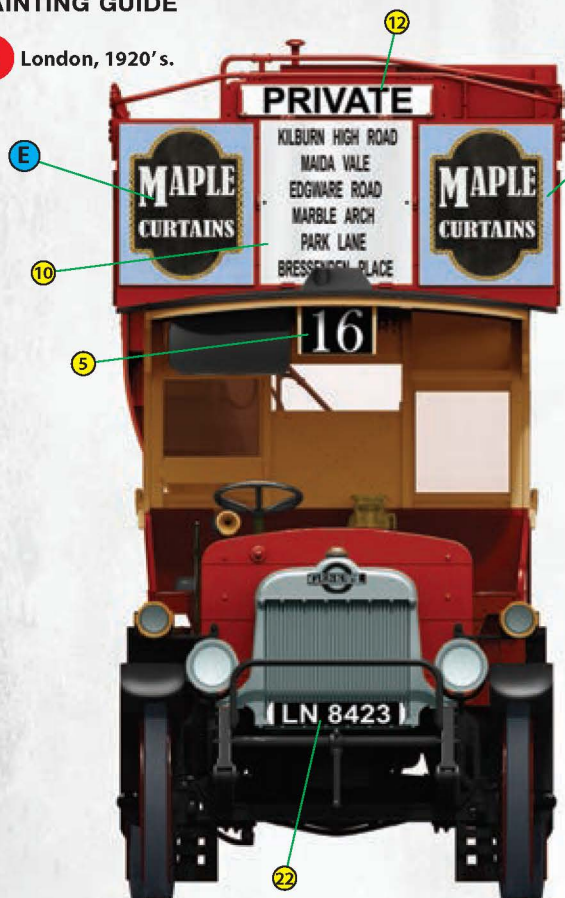

4 London, 1920's.

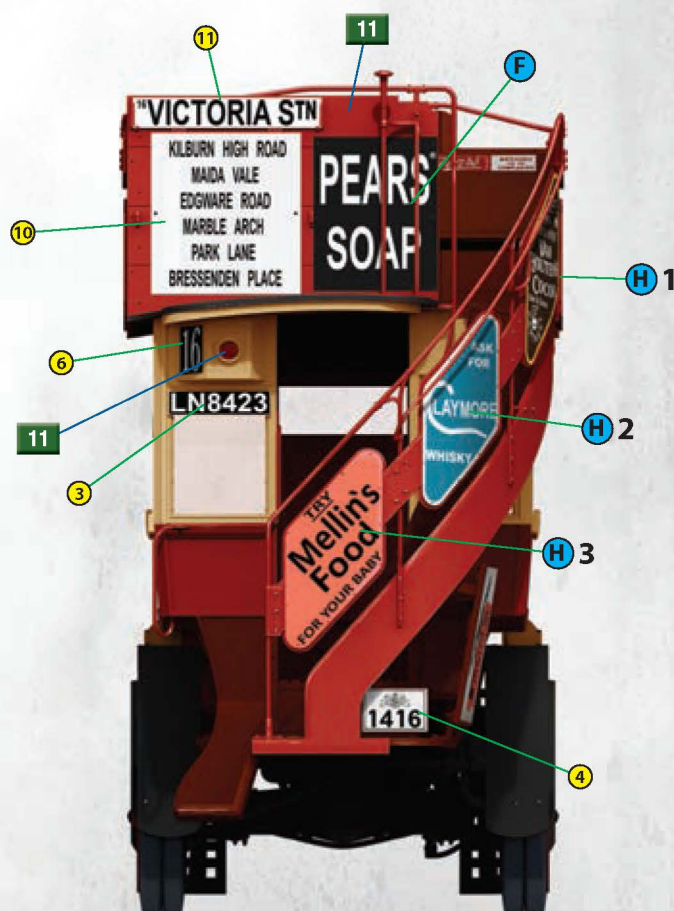

RELATED ITEMS

LGOC B-TYPE LONDON OMNIBUS

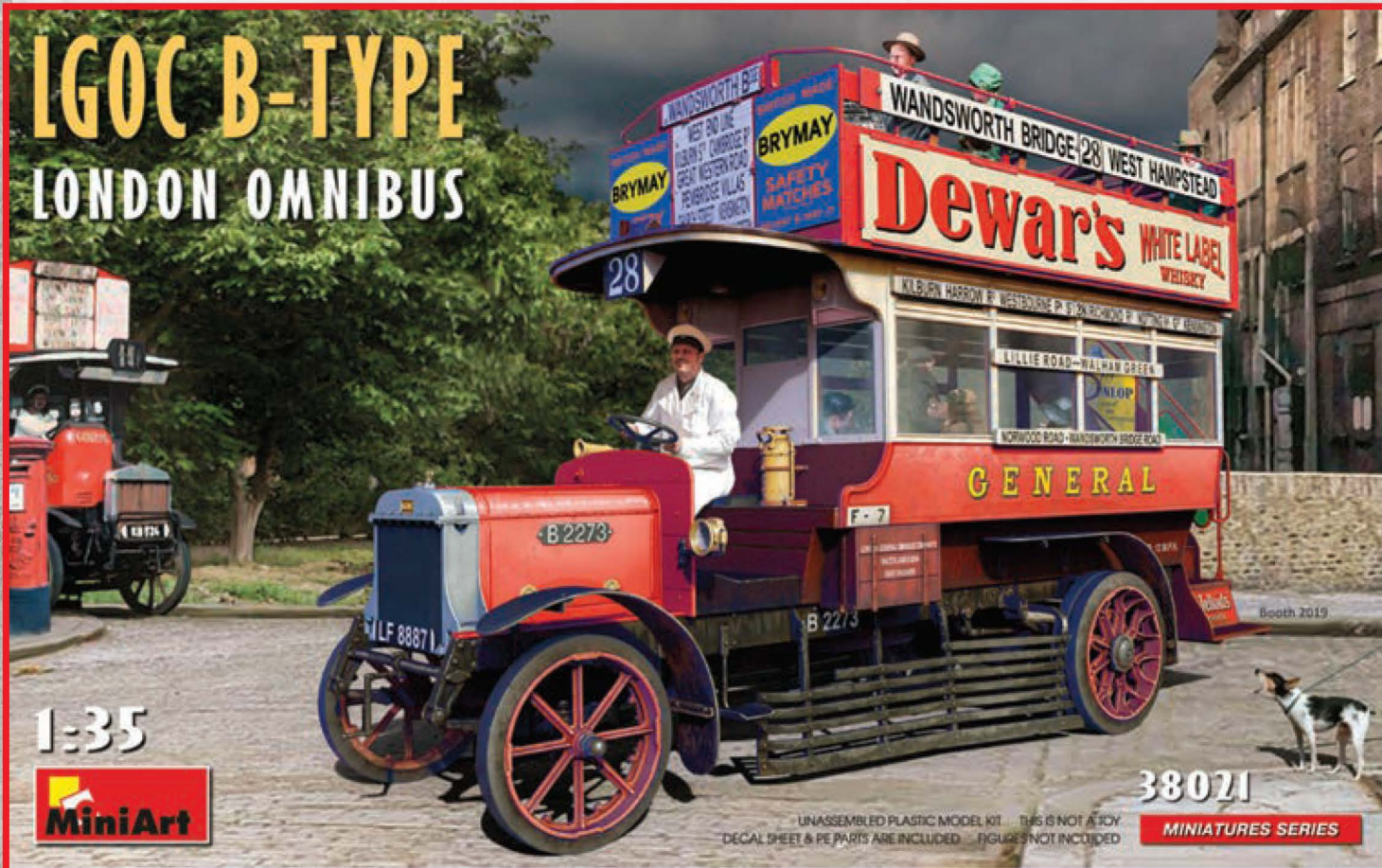

1:35

MiniArt

38021

UNASSEMBLED PLASTIC MODEL KIT THIS IS NOT A TOY
DECAL SHEET & PE PARTS ARE INCLUDED FIGURES NOT INCLUDED

MINIATURES SERIES

B-TYPE MILITARY OMNIBUS



1:35

MiniArt

39001

WW I MILITARY MINIATURES SERIES

UNASSEMBLED PLASTIC MODEL KIT
KIT CONTAINS MODEL OF BUS
PE PARTS INCLUDED
THIS IS NOT A TOY

A



B



C

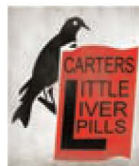

D



E



F

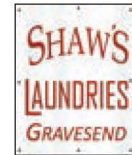

G



H



2



2



3



3

